

Foster Prep Station with LCD28 Controller



Service Manual



ISO 14001



ISO 9001



Contents

Manual Information & Health & Safety Notes	1
Environmental Management Policy	2
Disposal Requirements	2
Prep Station Description	3
Controller Operation	3 to 4
Alarma & Warnings	4 to 5
Parameter Setting	5
Controller Parameter List	6
General Arrangement	7 to 8
Parts List	9
Technical Details	10
Wiring Diagram	11
Troubleshooting & Notes	12 to 14









Service Manual Information

The products and all information in this manual are subject to change without prior notice.

We assume by the information given that the person(s) working on these refrigeration units are fully trained and skilled in all aspects of their workings. Also that they will use the appropriate safety equipment and take or meet precautions where required.

The service manual does not cover information on every variation of this unit; neither does it cover the installation or every possible operating or maintenance instruction for the units.

Health & Safety Warnings and Information

	Make sure the power supply is turned off before making any electrical repairs.
	To minimise shock and fire hazards, please do not plug or unplug the unit with wet hands.
	During maintenance and cleaning, please unplug the unit where required.
	Care must be taken when handling or working on the unit as sharp edges may cause personal injury, we recommend the wearing of suitable PPE.
	Ensure the correct moving and lifting procedures are used when relocating a unit.
	Do NOT use abrasive cleaning products, only those that are recommended. Never scour any parts of the refrigerator. Scouring pads or chemicals may cause damage by scratching or dulling polished surface finishes.
	Failure to keep the condenser clean may cause premature failure of the motor/compressor which will NOT be covered under warranty policy.
	Do NOT touch the cold surfaces in the freezer compartment. Particularly when hands are damp or wet, skin may adhere to these extremely cold surfaces and cause frostbite.
	Please ensure the appropriate use of safety aids or Personnel Protective Equipment (PPE) are used for you own safety.

Environmental Management Policy for Service Manuals and Duets.

Product Support and Installation Contractors

Foster Refrigerator recognises that its activities, products and services can have an adverse impact upon the environment. The organisation is committed to implementing systems and controls to manage, reduce and eliminate its adverse environmental impacts wherever possible, and has formulated an Environmental Policy outlining our core aims. A copy of the Environmental Policy is available to all contractors and suppliers upon request.

The organisation is committed to working with suppliers and contractors where their activities have the potential to impact upon the environment. To achieve the aims stated in the Environmental Policy we require that all suppliers and contractors operate in compliance with the law and are committed to best practice in environmental management.

Product Support and Installation contractors are required to:

1. Ensure that wherever possible waste is removed from the client's site, where arrangements are in place all waste should be returned to Foster Refrigerator's premises. In certain circumstances waste may be disposed of on the client's site; if permission is given, if the client has arrangements in place for the type of waste.
2. If arranging for the disposal of your waste, handle, store and dispose of it in such a way as to prevent its escape into the environment, harm to human health, and to ensure the compliance with the environmental law. Guidance is available from the Environment Agency on how to comply with the waste management 'duty of care'.
3. The following waste must be stored of separately from other wastes, as they are hazardous to the environment: refrigerants, polyurethane foam, and oils.
4. When arranging for disposal of waste, ensure a waste transfer note or consignment note is completed as appropriate. Ensure that all waste is correctly described on the waste note and include the appropriate six-digit code from the European Waste Catalogue. Your waste contractor or Foster can provide further information if necessary.
5. Ensure that all waste is removed by a registered waste carrier, a carrier in possession of a waste management licence, or a carrier holding an appropriate exemption. Ensure the person receiving the waste at its ultimate destination is in receipt of a waste management licence or valid exemption.
6. Handle and store refrigerants in such a way as to prevent their emission to atmosphere, and ensure they are disposed of safely and in accordance with environmental law.
7. Make arrangements to ensure all staff who handle refrigerants do so at a level of competence consistent with the City Guilds 2078 Handling Refrigerants qualification or equivalent qualification.
8. Ensure all liquid substances are securely stored to prevent leaks and spill, and are **not** disposed of to storm drains, foul drain, or surface water to soil.

Disposal Requirements

If not disposed of properly all refrigerators have components that can be harmful to the environment. All old refrigerators must be disposed of by appropriately registered and licensed waste contractors, and in accordance with national laws and regulations.

Foster Prep Station Descriptions

The range consists of 2 to 5 door models with a storage capacity ranging from 270 to 720 litres. The cabinets are manufactured as a one piece foam shell with easy clean stainless steel exterior. All conform to current legislation and exceed the Montreal protocol using zero ODP refrigerants and insulation. The temperature is controlled by a LAE microprocessor control with digital temperature display. Easy accessible condensing unit fitted at the rear for ease of servicing. The standard refrigeration system is integral with an air-cooled condensing unit with the refrigerant distribution into the evaporator controlled by capillary. The cooled air is circulated through the evaporator, via the fan into the storage area. Coated coils prevent corrosion and prolong refrigeration life. Easy to read temperature display with wipe clean finish. Wide magnetic gasket giving a positive door seal.

Temperature and Capacities

Model	FPS 2HR	FPS 3HR	FPS 4HR	FPS 5HR
Counter Base Storage Temperature	+1 to +4°C	+1 to +4°C	+1 to +4°C	+1 to +4°C
Pan Storage Temperature (with Lids Fitted)	+3 to +5°C	+3 to +5°C	+3 to +5°C	+3 to +5°C
Nett Capacity (litres)	270	420	570	720
Pan Clear Opening	1058 x 305	1640 x 305	2222 x 305	2804 x 305
Max Number of 1/3 Pans Per Opening	6	9	12	16
Door Opening (w x h) Per Door	450 x 604	450 x 604	450 x 604	450 x 604
Door Opening Depth	1345	1345	1345	1345
Shelf Size	417 x 410	417 x 410	417 x 410	417 x 410
Number of Shelves Supplied Per Unit	4	6	8	10
Number OF Castors Supplied	5	5	5	6

Controller Operation

LCD 28CS4E-B (00-555739) Controller fitted up to June 2007

Operation Guidelines



LCD 16 Display (00-555740)

Initial Start Up.

Start Up & self Test:

The indication is only displayed during the first three seconds following the mains electrical power being applied to the unit. During this period the controller performs a self-check.

Once the self-check has been completed will be displayed.

Press and hold for three seconds. The unit will start and the air temperature will be displayed.

Check temperature set point.

Important to note that the ability to increase and decrease the set point is not a function available to the user as the set point is fixed. To make adjustments to the set point it is necessary to access the parameter and alter SPL and SPH accordingly.

Check set point by pressing the button

To increase set point press + until required temperature is displayed.

To decrease set point press + until required temperature is displayed.

Factory Temperature Set Point

Refrigerator +1°C to +4°C

Exit from set up occurs after 10 seconds if no button is pressed.

Manual Defrost.

To initiate a manual defrost press and hold



dEF

will be displayed then release



On completion of the defrost **REC** will be displayed until the cabinet temperature is achieved and then it will revert to displaying the normal cabinet temperature.

Set Unit to Standby.

Press



display shows

OFF

Standby Indication

This indication is displayed while the unit is not operating but with mains power applied to the unit. This mode may be used for internal cleaning regimes and short periods when the unit is not required.

For extended periods of inactivity the mains supply should be isolated.

Alarm and Warnings

High temperature alarm

HI Will be displayed.

The alarm will sound but can be silenced by pressing any of the buttons, however it will return after the pre-set designated period. The unit returning to normal operating temperature will automatically cancel the alarm.

Possible Causes: Evaporator fan not working. Restricted airflow through airduct. Evaporator iced up. Compressor not working.

Low temperature alarm.

LO Will be displayed.

The alarm will sound but can be silenced by pressing any of the buttons and the unit will continue to operate, however it will return after the pre-set designated period. The unit returning to normal operating temperature will automatically cancel the alarm.

Possible Causes: Controller faulty (not switching compressor off). Compressor secondary relay will not de-energise (low temperature models).

Door Open Alarm. (Only applies to cabinets fitted with door switches.)

DO Will be displayed.

The alarm will sound but can be silenced by pressing.



The display will continue to display the alarm message until cancelled by shutting the door.

If the alarm cannot be cancelled by doing this call your Foster Authorised Service Company.

Possible Causes: Faulty door switch. Door left open for more than 5minutes.

High Pressure Alarm (Only applies to machines fitted with a condenser probe).

HP Will be displayed

This alarm relate to the condenser which must be checked and cleaned at regular intervals the frequency being determined by site conditions.

The alarm will sound but can be silenced by pressing any of the buttons and the unit will continue to operate, however it will return after the pre-set designated period. The unit returning to normal operating temperature will automatically cancel the alarm.

Possible Causes: Condenser fan not working. Condenser blocked/ dirty. Condenser obstructed.

Air Temperature Probe Failure.

E1 Will be displayed.

The alarm will sound but can be silenced by pressing any button.

There is no further action that can be taken by the user in this instance. During this period the unit will continue to operate but have a reduced performance.

Action: Replace Probe. Check Connections.

Evaporator Temperature Probe Failure. (Automatic Defrost Cabinets Only)

E2 Will be displayed.



The alarm will sound but can be silenced by pressing any button.

There is no further action that can be taken by the user in this instance. During this period the unit will continue to operate satisfactorily, but this failure will have an effect on the defrost and therefore efficiency if allowed to continue.

Action: Replace Probe. Check Connections



Information Menu

Pressing and releasing  activates the information menu. From this menu you can display the temperature relating to T1 (air probe), T2 (evaporator probe, if fitted) and T3 (condenser probe, if fitted). The maximum temperature (THI) and the minimum temperature (TLO) the cabinet has achieved since it was last re-set. The total operating time of the condenser (CND), since it was last cleaned, and the keyboard status (LOC).

The information to be displayed can be selected sequentially by pressing  repeatedly or scrolling through the menu using the  or  buttons.

Once selected press  to display the value

Exit from the info menu by pressing  or is automatic after 6 seconds if no buttons are pressed.



To reset the temperature settings recorded in THI and TLO and the hours counted in CND, access the info menu press  to display the value plus  simultaneously for resetting to be completed.

To check the LOC status scroll through to LOC, press  to display status – YES to lock keys. – NO to leave keys accessible.

NOTE: with the keys locked it is not possible to turn the unit OFF or ON or to check the set point



Parameter Setting and Adjustment

It is strongly advised that before adjusting any Service Parameters a thorough understanding of the following instructions should be obtained.

The parameters are accessed by pressing the following keys in succession  + “set” +  and keeping them pressed for 5 seconds.

After this period the first parameter ‘SCL’ will be displayed.



Press button  to pass from one parameter to the next and button  to go back.

Press  to display the value +  or  to change it.

Exit from set up is by pressing  or is automatic if no buttons are pressed for 30 seconds

NOTE:

When receiving a replacement controller the unit will be set with the default settings. Change the settings to those relating to the particular model. After changing parameter ‘SCL’ from ‘1’ to ‘2’ moving through parameters ‘SPL’, ‘SP’, ‘FDD’, ‘IISL’ and ‘IISP’ you may find that ‘-or’ will be displayed. ‘-or’ indicates that the control setting is out of range.

To get the parameter back into range, for example ‘SPL’, press  to display the value +  continue pressing both buttons until the display shows the temperature required then release both buttons. Use the same procedure to adjust all of the parameters displaying ‘-or’.

Fuzzy Logic is not incorporated in this model as no door switches are fitted.

Controller parameters for models manufactured prior to March 1st 2006

The parameter settings for the cabinets produced prior to March 1st 2006 can be altered to the following parameter lists and will function as described above.

Note

Parameter FPC is not included in this version.

LCD 28CS4E-B (00-555735) Controller Parameter lists

Note: On early versions of the controller parameter 'FPc' is not included in the set up, this will have no bearing on the operational function of the controller.

Mnem.	Definition	Min.	Max	Default	Dim.	VALUES (A)
ScL	Readout scale	1°C; 2°C; °F		1°C	flag	2
SPL	Minimum setpoint [I]	-30	SPH	-25	°C	1
SPh	Maximum setpoint [I]	SPL	30	10	°C	4
SP	Setpoint [I]	SPL	SPH	-20	°C	1
hYS	Thermostat hysteresis [I]	0.1	10	2.5	°K	3
crt	Minimum compressor rest time	0	30	1	min.	1
cdc	10 min. run cycle with PF1	0	10	6	min.	6
cSd	Compressor Stop delay after door open	0	30	1	min.	1
dFr	Defrost frequency [I]	0	24	3	1/24h	4
dLi	Defrost end temperature	-30	30	15	°C	20
dto	Maximum defrost duration	1	120	20	min.	20
dtY	Defrost type	FAN; ELE; GAS		ELE	flag	OFF
drn	Drain down time	0	30	3	min.	2
ddY	Display control during defrost	0	60	10	min.	10
Fid	Fan operation in defrost	NO	YES	NO	flag	YES
Fdd	Evaporator. Fan re-start	-30	30	-50	°C	10
Ftc	Fan timed control [I]	NO	YES	YES	flag	NO
FPc	Evaporator fan On / Off Ratio	0	3	1	flag	0
Atl	Low temperature alarm	-12	0	0	°K	-5
Ath	High temperature alarm	0	12	5	°K	5
Atd	Temperature alarm delay	0	120	30	min.	90
Ado	Door alarm delay	0	30	5	min.	5
Aht	Condenser HP Alarm	0	70	60	°C	60
Ahm	AHT alarm management	NON; ALR; STP		NON	flag	NON
Acc	Condenser cleaning	0	52	0	wks	0
hdS	Eco->Heavy Duty sensitivity	1	5	3	flag	3
11SM	2nd parameter set management	NON; MAN; HDD		NON	flag	NON
11SL	Minimum setpoint [II]	-30	IISH	-25	°C	-25
11SH	Maximum setpoint [II]	IISL	30	10	°C	10
11SP	Setpoint [II]	IISL	IISH	-20	°C	-20
11HY	Thermostat hysteresis [II]	0.1	10	3	°K	3
11dF	Defrost frequency [II]	0	24	1	1/24h	1
11Ft	Fan timed control [II]	NO	YES	NO	flag	NO
Sb	Stand By button function	NO	YES	YES	flag	YES
dS	Door switch enabling	NO	YES	NO	flag	NO
oAu	AUX Output Control	NON; 0-1; ALR		ALR	flag	NON
oS1	Air probe offset	-12.5	12.5	0	°K	0
t2	Evaporator. Probe enabling	NO	YES	YES	flag	NO
OS2	Evaporator. Probe offset	-12.5	12.5	0	°K	0
T3	Condenser. Probe enabling	NO	YES	NO	flag	NO
oS3	Condenser. Probe offset	-12.5	12.5	0	°K	0
tLd	Logging Temp. Delay	1	30	5	min.	5
Sim	Display slowdown	0	100	3	exp.	3
Adr	Unit address	1	255	1	exp.	1

Cabinet General Arrangement

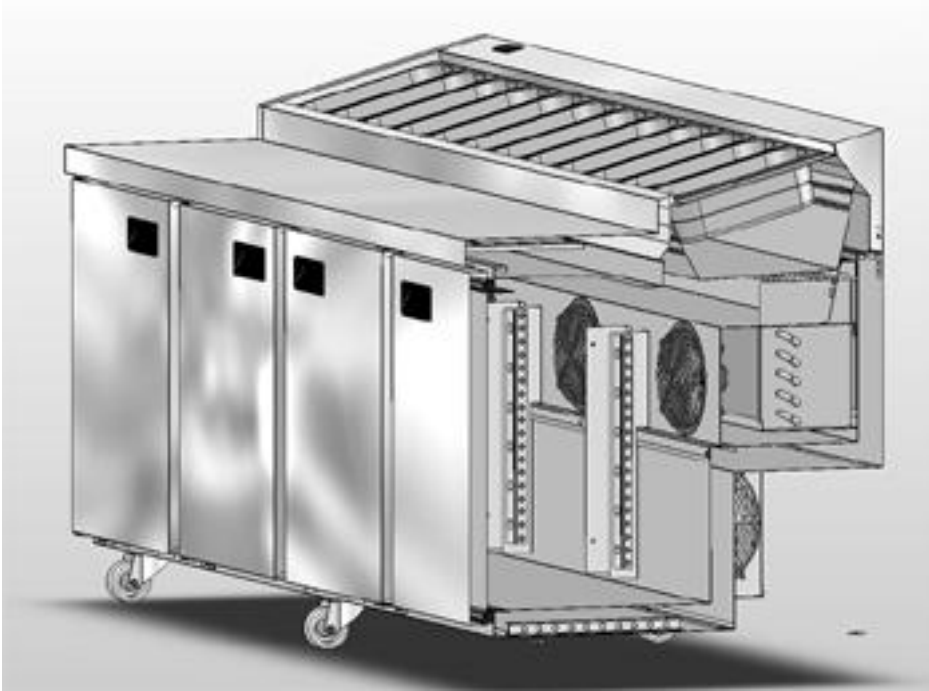

Evaporator Assembly

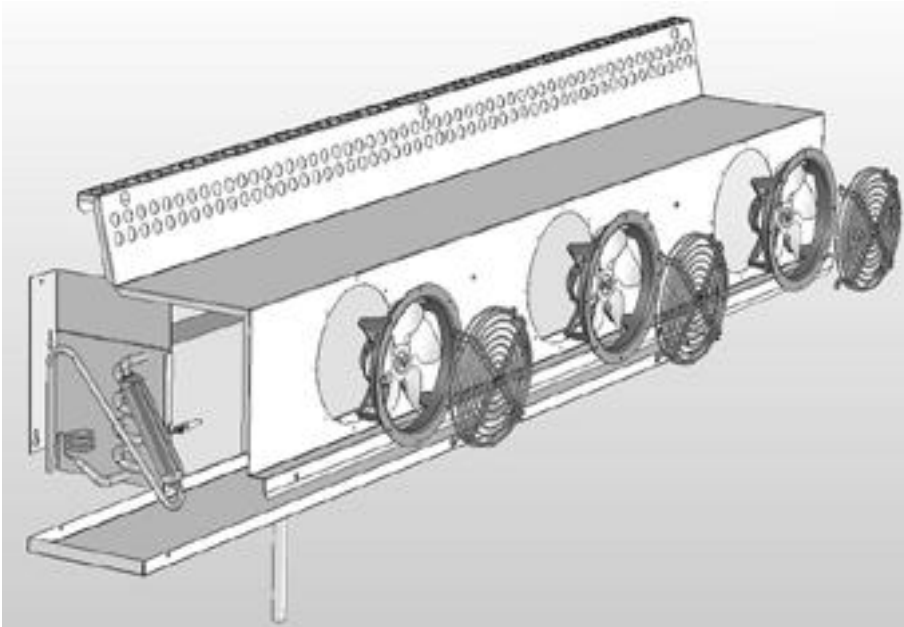

FPS2HR & FPS3HR Condensing Unit Arrangement.

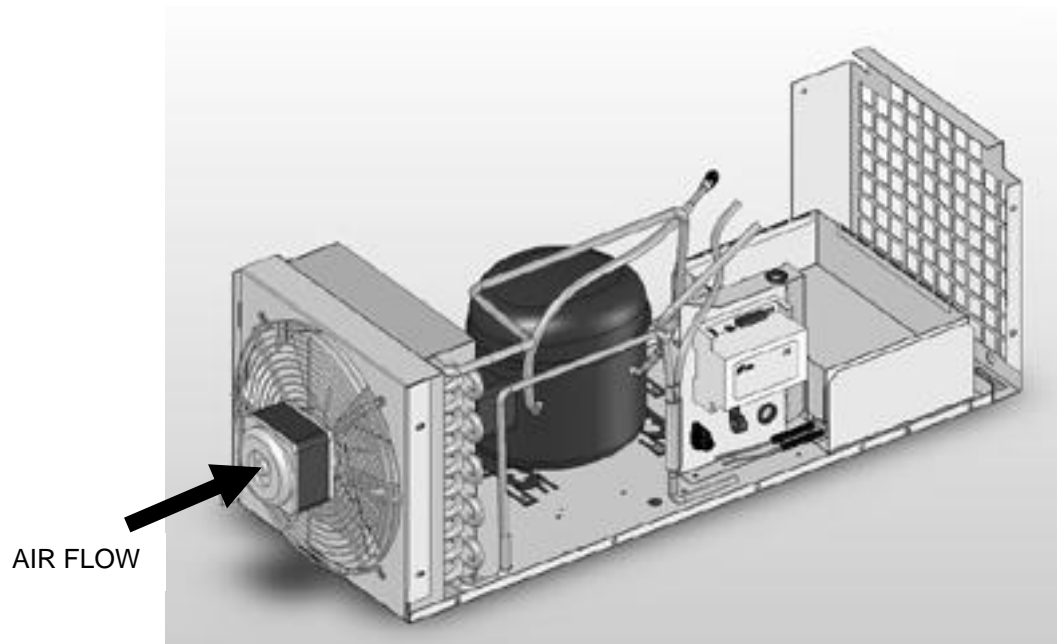

FPS4HR & FPS5HR Condensing Unit Arrangement.

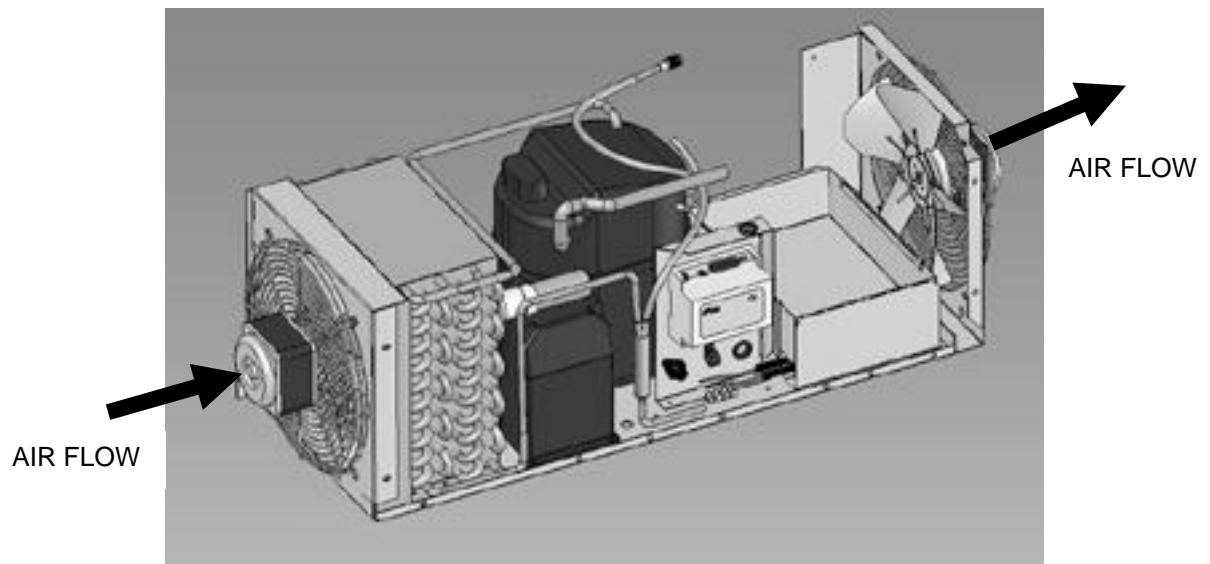

Parts List

Item	Description	Part Number	Model
Compressor	GP12TB	00-555666	FPS 2HR
Compressor	GP16TB	00-555668	FPS 3HR
Compressor	GS26TB	00-555669	FPS 4HR FPS 5HR
Condenser Fan Motor	Grid Mount 18W	00-555819	FPS 2HR FPS 3HR
Condenser Fan Motor	Grid Mount 16W	15470027	FPS 4HR FPS 5HR
Fan Blade	34° 254mm CCW Rotation	15470213	FPS 2HR FPS 3HR FPS 4HR FPS 5HR
Fan Blade	34° 254mm CW Rotation	15470212	FPS 4HR FPS 5HR
Condenser Coil		01-255616-01	FPS 2HR
Condenser Coil		01-254927-01	FPS 3HR
Condenser Coil		01-255618-01	FPS 4HR
Condenser Coil		01-255628-01	FPS 5HR
Vaporiser Heater	Rod Heater 250w-240v Pre-formed	15240025	FPS 2HR FPS 3HR FPS 4HR FPS 5HR
Vaporiser Tray		01-254947-01	FPS 2HR FPS 3HR FPS 4HR FPS 5HR
Evaporator Coil		01-255610-01	FPS 2HR
Evaporator Coil		01-254957-01	FPS 3HR
Evaporator Coil		01-255612-01	FPS 4HR
Evaporator Coil		01-255614-01	FPS 5HR
Evaporator Fan Motor	5W 172mm 31deg	00-555815	FPS 2HR FPS 3HR FPS 4HR FPS 5HR
Fan Guard	Black	00-555813	FPS 2HR FPS 3HR FPS 4HR FPS 5HR
Temperature Controller		00-555739	FPS 2HR FPS 3HR FPS 4HR FPS 5HR
Temperature Display	Display + Ribbon Cable	16240105	FPS 2HR FPS 3HR FPS 4HR FPS 5HR
Air Probe	Probe Type NTC	00-555775	FPS 2HR FPS 3HR FPS 4HR FPS 5HR
Door Gasket	522 x 656mm Magnetic	01-255146-01	FPS 2HR FPS 3HR FPS 4HR FPS 5HR
Hinge Bracket RH Top		01-255160-01	FPS 2HR FPS 3HR FPS 4HR FPS 5HR
Hinge Bracket RH Bottom		01-255158-01	FPS 2HR FPS 3HR FPS 4HR FPS 5HR
Hinge Bracket LH Bottom		01-254439-01	FPS 2HR FPS 3HR FPS 4HR FPS 5HR
Hinge Bracket LH Top		01-254419-01	FPS 2HR FPS 3HR FPS 4HR FPS 5HR
Ladderack	446mm 6 Keyholes	01-233169-03	FPS 2HR FPS 3HR FPS 4HR FPS 5HR
Shelf Clip	S/S 430 FPS	01-255900-01	FPS 2HR FPS 3HR FPS 4HR FPS 5HR
Shelf	c/w Upstand PMC2-5 HFT/RT	15271657	FPS 2HR FPS 3HR FPS 4HR FPS 5HR
Castor	80mm Swivel	00-555708	FPS 2HR FPS 3HR FPS 4HR FPS 5HR
Castor	80mm Swivel Braked	00-555709	FPS 2HR FPS 3HR FPS 4HR FPS 5HR
Leg	80/110mm	00-554608	FPS 2HR FPS 3HR FPS 4HR FPS 5HR







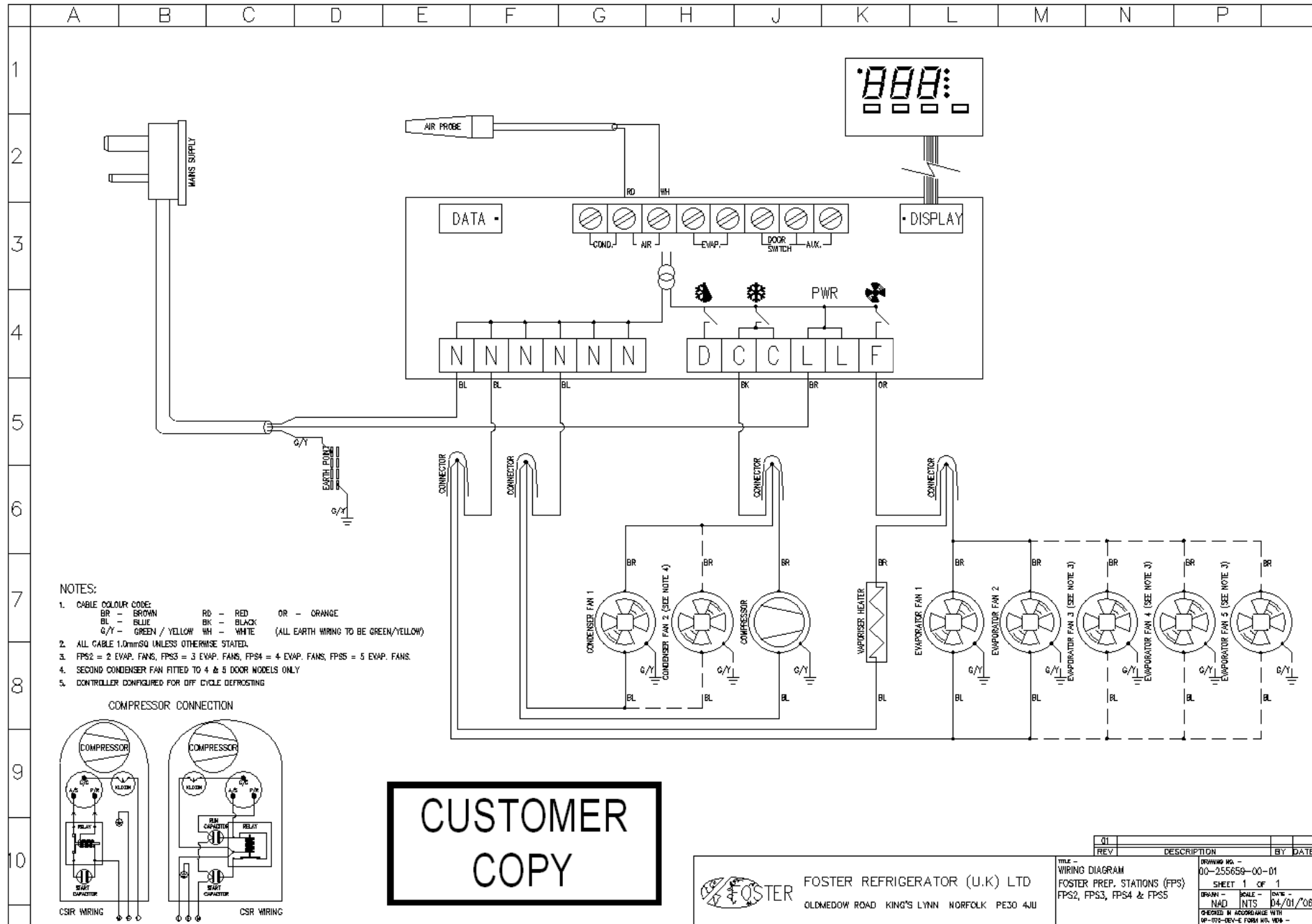



Technical Details









MODEL		FPS 2HR	FPS 3HR	FPS 4HR	FPS 5HR
Refrigerant		R134a	R134a	R134a	R134a
Refrigerant Grams		375	500	575	800
Compressor		GP12TB	GP16TB	GS26TB	GS26TB
Capillary Size		3m x 042	3m x 054	3m x 064	3m x 064
Defrost Type		Timed Off Cycle	Timed Off Cycle	Timed Off Cycle	Timed Off Cycle
Condensate Vaporisation		Electric	Electric	Electric	Electric
Standard Voltage		220-50-1	220-50-1	220-50-1	220-50-1
Power Consumption	Watts	690	875	1140	1170
	Amps	4.4	5.6	7.4	7.6
Fuse Rating		13 amp	13 amp	13 amp	13 amp
Thermal Heat Rejection		1050	1620	2240	2280
Net Weight Kgs		164	207	245	265

Wiring Diagram for Models using the LCD 28CS4E-B (00-555735)



Troubleshooting

Problem	Possible Cause	Solution
Compressor will not start	No voltage in socket	Use voltmeter to check
	Electrical conductor or wires may be cut	Use ohmmeter to check for continuity
	 Defective electrical component: thermostat, relay, thermal protector etc	Replace defective component
	Compressor motor has a winding open or shorted	Measure ohmic resistance of main and auxiliary winding using ohmmeter. Compare with correct values
	 Compressor stuck	Change compressor
	Temperature control contacts are open	Repair or replace the contacts
	Incorrect wiring	Check wiring diagram and correct
	Fuse blown or circuit breaker tripped.	Replace fuse or reset circuit breaker
	Power cord unplugged	Plug in power cord.
	Controller set too high	Set controller to lower temperature.
Cabinet in defrost cycle	Wait for defrost cycle to finish	
The temperature is too cold	Controller is set at a very cold position	Set to warmer position and check if the compressor stops according to controllers operating range.
	Controller does not disconnect the condensing unit	Check the insulation of the thermostat. If problem persists, change the thermostat
	Control contacts are stuck closed	Change the control. Check amperage load
	Defective or incorrect temperature control	Determine correct control and replace.
The temperature is not cold enough	Controller is set at a very warm position	Adjust to colder setting
	 Condenser is dirty	Clean condenser
	 The refrigerator has been placed at an inadequate location	The unit must not be near stoves, walls that are exposed to the sun, or places that lack sufficient air flow.
	 Compressor is inefficient or there is a high pressure due to the air in the system	If there is air in the system, purge and recharge
	  Iced up evaporator coil	Check temperature control, refrigerant charge, and defrost mechanism. Remove all ice manually and start over.
	Restriction in system	Locate exact point of restriction and correct
	 The refrigerator has been used improperly	The shelves must never be covered with any type of plastic or other material that will block the circulation of cold air within the refrigerator.
	 Too many door openings	Advise user to decrease if possible
	 Excessive heat load placed in cabinet	Advise user not to put in products that are too hot.
	 The refrigerator has been overcharged with the refrigerant gas	Check to see if condensation or ice crystals have formed on the suction line. If so, charge with the correct amount of gas.

		The refrigerant gas is leaking	Find the location of gas leak in order to seal and replace the defective component. Change the drier. Perform a good vacuum and recharge unit.
		The evaporator and/or condenser fans are not working	Check electrical connections and make sure that the fan blade isn't stuck. Replace the fan motor if it doesn't work.
		Blocking air flow	Re-arrange product to allow for proper air flow. Make sure there is at least four inches of clearance from evaporator.
		Fuse blown or circuit breaker tripped	Replace fuse or reset circuit breaker.
Electrical Shocks		Wires or electrical components are in direct contact with metallic parts.	Check for appropriate insulation on the connections of each component.
Noise		The refrigerator is not properly levelled	Check if the noise goes away after you level the refrigerator
		The condenser is not fastened correctly. Copper tubing is in contact with metal	While the compressor is working, check to see if metal parts are in contact with one another and/or if the screws that fasten the condenser are tightened.
		The evaporator and/or condenser fans are loose	Check if the fans are securely fastened. Also, check if the fan blades are loose, broken or crooked. If so, change the faulty blade.
		Compressor has an internal noise	If the noise persists after all other measures have been taken, it may be originating from the compressor.
		Loose part(s)	Locate and tighten loose part(s)
Extreme condensation inside the refrigerator		Controller is set at a very cold position	Set the controller to a warmer position & check to see if compressor stops as should.
		The outside environment's relative humidity is very high (over 75%)	This type of occurrence is caused by local climatic conditions and not by the refrigeration unit.
		The refrigerator door wont shut completely	Check the door and/or the magnetic gasket. Adjust the door hinges if needed; replace the gasket if broken.
		The refrigerator had been placed at an inadequate location	The unit must not be near sources that produce too much heat.
No illumination (Glass door models only)		The light switch is "off" position	Press the light switch to "on" position
		False contact on the light switch, the fluorescent tube, or the ballast	Inspect all connections
		Light switch, ballast and/or fluorescent tube are damaged	Replace the damaged component.
Condensing unit runs for long periods of time		Excessive amount of warm product placed in cabinet	Advise user to leave adequate time for products to cool down
		Prolonged door opening or door ajar	Advise user to ensure doors are closed when not in use and to avoid opening doors for long periods of time.
		Door gasket(s) not sealing properly	Ensure gaskets are snapped in completely. Remove gasket and wash with soap and water. Check condition of gasket & replace if necessary



Dirty condenser coil

Clean condenser coil

Evaporator coil iced over

Unplug unit and allow coil to defrost. Make sure thermostat is not set too cold. Ensure that door gasket(s) are sealing properly. Select manual defrost and ensure system works.

Notes



Foster European Operations

France

Foster Refrigerator France SA

Tel: (33) 01 34 30 22 22. Fax: (33) 01 30 37 68 74.

Email: commercial@fosterfrance.com

Germany

Foster Refrigerator Gmbh,

Tel: (49) 781 990 7840. Fax (49) 781 990 7844.

Email: info@foster-gmbh.de

Foster Refrigerator

Oldmedow Road

Kings Lynn

Norfolk

PE30 4JU

Tel: 0843 216 8833

Fax: 0843 216 4707

Website: www.fosterrefrigerator.co.uk

Email: support@foster-uk.com

a Division of 'ITW (UK) Ltd'

FPS COUNT/ LCD28/SM 07/10