

# Modular Blast Chillers/Freezers

## Page

|   |              |
|---|--------------|
| <b>SECTION 3.1 Modular Blast Chillers &amp; Freezers</b>                                    | <b>24</b>    |
| <b>1. Operating Instructions for the Mk4 Microprocessor - May 2000</b>                      | <b>25</b>    |
| 1.1 Introduction  | 25           |
| 1.2 General System Operation  | 25           |
| 1.3 Controller Front Panel  | 25           |
| 1.4 Indicating Displays and LED's   | 25           |
| Procedure for modifying modular blast chiller from ELM Mk3/3A (ELM) Controller              | 26           |
| 1.5 Mk4 Blast Chiller Controller Outline Operating Guide                                    | 27           |
| 1.6 Operation   | 28           |
| 1.7 Error Annunciation  | 28           |
| 1.8 Hard or Soft Chilling   | 29           |
| 1.9 User Programme Settings   | 29           |
| 1.10 Programme Setting and Control Parameter Adjustment                                     | 29           |
| 1.11 Service Parameters   | 29-31        |
| 1.12 Controller Model Selection   | 31-32        |
| 1.13 Electrical Connections   | 33           |
| 1.14 Resistance Values  | 33           |
| <b>SECTION 3.2 Modular Blast Chillers &amp; Freezers</b>                                    | <b>34</b>    |
| <b>2. Operating Instructions for the Mk2 &amp; 3 Microprocessor - Feb. 1997 to May 2000</b> | <b>34</b>    |
| 2.1 User Operation Guidelines   | 34-35        |
| 2.2 Temperature Controller Operation  | 35           |
| 2.3 Operation Flow Chart  | 36           |
| 2.4 Programme Setting Flow Chart  | 37           |
| 2.5 Using the Blast Chiller Freezer   | 38           |
| 2.6 Standard Controller Programme Settings  | 38           |
| 2.7 Electrical Connections  | 39           |
| 2.8 Display Fascia Panel  | 39           |
| 2.9 Operation   | 40           |
| 2.10 Surroundings and External Influences   | 40           |
| 2.11 Program Settings and Control Parameter Adjustments                                     | 41           |
| 2.12 Program and Control Parameters Settings  | 41-42        |
| 2.13 Error Annunciation and Fault Finding   | 42           |
| 2.14 Controller Detail  | 43           |
| 2.15 Food Probe Detail  | 44           |
| <b>SECTION 3.3 Modular Blast Chillers &amp; Freezers</b>                                    | <b>45</b>    |
| <b>3. Operating Instructions for the Mk1 Microprocessor - Up to February 1997</b>           | <b>45</b>    |
| 3.1 Blast Chiller Introduction  | 45           |
| 3.2 Controller Introduction   | 45           |
| 3.3 Controller - The Display  | 46           |
| 3.4 Chiller Operation   | 47           |
| 3.5 Controller Operating Instructions   | 48           |
| 3.6 Chiller Programming   | 49           |
| 3.7 Chill Cycle Setting   | 50           |
| 3.8 Failure Situations  | 50           |
| 3.9 Test Outputs  | 50           |
| 3.10 Parameter Settings   | 51           |
| <b>3.11 Installation Instruction</b>  | <b>52</b>    |
| <b>3.12 Installation Instruction Diagrams</b>   | <b>52-54</b> |
| <b>3.13 Probes Positions</b>  | <b>55</b>    |

# **SECTION 1**

## **Cabinet & Counter**

### **BLAST CHILLERS & FREEZERS**



# Cabinet Blast Chiller/Freezer Technical Data

| Model      | Refrigerant | Refrigerant Charge | Compressor       | Expansion Valve/Orifice | Defrost Type | Voltage | Phase (Hz) | Power Consumption |       | Mains supply Amps | Chilling Capacity | Freezing Capacity |
|------------|-------------|--------------------|------------------|-------------------------|--------------|---------|------------|-------------------|-------|-------------------|-------------------|-------------------|
|            |             |                    |                  |                         |              |         |            | Amps              | Watts |                   |                   |                   |
| CBC 10     | R404A       | 1300 grms          | CAJ 9480Z        | TES2-N/<br>NO 01        | Hot Gas      | 230     | 1-50       | 4.6               | 1061  | 13                | 10 kg             | -                 |
| CBC 20     | R404A       | 1600 grms          | CAJ 9513Z<br>MHR | TES2-N/<br>NO 02        | Hot Gas      | 230     | 1-50       | 6.3               | 2032  | 13                | 20 kg             | -                 |
| BC 10      | R404A       | 1300 grms          | CAJ 9480Z        | TES2-N/<br>NO 01        | Hot Gas      | 230     | 1-50       | 4.7               | 1037  | 13                | 10 kg             | -                 |
| BC 20      | R404A       | 1500 grms          | CAJ 9513Z        | TES2-N/<br>NO 02        | Hot Gas      | 230     | 1-50       | 6.6               | 1513  | 13                | 20 kg             | -                 |
| BC 35      | R404A       | 2400 grms          | CAJ 4519Z        | TES2-N/<br>NO 03        | Hot Gas      | 230     | 1-50       | 10.2              | 5400  | 16                | 35 kg             | -                 |
| BC 50      | R404A       | N/A                | Remote           | TES2-N/<br>NO 04        | Electric     | 400     | 3-50       | -                 | 685   | 16                | 50 kg             | -                 |
| CBF 10     | R404A       | 1300 grms          | CAJ 2446Z        | TES2-N/<br>NO 01        | Hot Gas      | 230     | 1-50       | 3.9               | 806   | 13                | -                 | 10 kg             |
| CBF 20     | R404A       | 1700 grms          | TAH 2480Z<br>BR  | TES2-N/<br>NO 02        | Hot Gas      | 400     | 3-50       | 3.4               | 2032  | 10                | -                 | 20 kg             |
| BF 10      | R404A       | 1100 grms          | CAJ 2446Z        | TES2-NL/<br>NO 00       | Hot Gas      | 230     | 1-50       | 3.9               | 1071  | 13                | -                 | 10 kg             |
| BF 20      | R404A       | 2000 grms          | TAH 2480Z        | TES2-NL/<br>NO 01       | Hot Gas      | 400     | 3-50       | 3.9               | 1932  | 13                | -                 | 20 kg             |
| BF 35      | R404A       | 2800 grms          | TAH 2511Z        | TES2-NL/<br>NO 01       | Hot Gas      | 400     | 3-50       | 4.2               | 2954  | 16                | -                 | 35 kg             |
| CBCF 10/5  | R404A       | 1300 grms          | CAJ 2432Z        | TES2-N/<br>NO 01        | Hot Gas      | 230     | 1-50       | 3.2               | 806   | 13                | 10 kg             | 5 kg              |
| CBCF 20/10 | R404A       | 1500 grms          | CAJ 2446Z        | TES2-NL/<br>NO 00       | Hot Gas      | 230     | 1-50       | 4.4               | 1102  | 13                | 20 kg             | 10 kg             |
| BCF 10/5   | R404A       | 1300 grms          | CAJ 2432Z        | TES2-NL/<br>NO 00       | Hot Gas      | 230     | 1-50       | 4.0               | 806   | 13                | 10 kg             | 5 kg              |
| BCF 20/10  | R404A       | 1500 grms          | CAJ 2446Z        | TES2-NL/<br>NO 00       | Hot Gas      | 230     | 1-50       | 6.9               | 1102  | 13                | 20 kg             | 10 kg             |
| BCF 35/15  | R404A       | 2400 grms          | TAH 2480Z        | TES2-NL/<br>NO 01       | Hot Gas      | 400     | 3-50       | 3.4               | 2204  | 10                | 35 kg             | 15 kg             |

# Roll-In Blast Chiller Technical Data

| Model Ref:                | EBC1             | EBCR 1           | MEBC 1           | MEBC 1W          | MEBC 2                        | MEBC 2W                       |
|---------------------------|------------------|------------------|------------------|------------------|-------------------------------|-------------------------------|
| Chilling Capacity         | 75 Kg            | 75 Kg            | 75 Kg            | 75 Kg            | 150Kg                         | 150Kg                         |
| Refrigerant Gas           | R 404A           | R404A            | R404A            | R404A            | R404A                         | R404A                         |
| Defrosting                | Electric         | Electric         | Electric         | Electric         | Electric                      | Electric                      |
| Cooling Capacity kw       | 5.6              | 5.6              | 6.4              | 6.4              | 12.0                          | 12.0                          |
| Compressor                | Remote           | Remote           | Remote           | Remote           | Remote                        | Remote                        |
| Fuse Rating               |                  |                  |                  |                  |                               |                               |
| Trolley Capacity          | 1 rack           | 1                | 1                | 1                | 1                             | 2                             |
| Capillary/Expansion Valve | TES-NL/<br>NO 05 | TES-NL/<br>NO 05 | TES-NL/<br>NO 05 | TES-NL/<br>NO 05 | TCAE-N-<br>R404A/<br>TCAE-No2 | TCAE-N-<br>R404A/<br>TCAE-No2 |
| Electrical Supply         | 230/1/50         | 230/1/50         | 230/1/50         | 230/1/50         | 230/1/50                      | 230/1/50                      |
| Nominal Amps              | 1.2              | 1.2              | 2.84             | 2.84             | 2.84                          | 2.84                          |
| Maximum Amps              | 6.9              | 6.9              | 13.9             | 13.9             | 13.9                          | 13.9                          |
| Max Amps During Defrost   | 3200             | 3200             | 3200             | 3200             | 3200                          | 3200                          |
| Mains Supply              | 16               | 16               | 16               | 16               | 16                            | 16                            |
| Chilling Capacity         | 75kg             | 75kg             | 75kg             | 75kg             | 150kg                         | 150kg                         |
| Freezing Capacity         | 15kg             | 15kg             | 15kg             | 15kg             | 30kg                          | 30kg                          |

# 1. OPERATING INSTRUCTIONS FOR THE Mk4 MICROPROCESSOR

## 1.1 INTRODUCTION

The MK4 cabinet and counter Blast Chiller Controller is a drop in replacement for the Mk2, Mk3 and Mk 3a Blast Chiller Controller. It is a microprocessor based temperature controller which may be fully programmed to perform process operations for various Chilling/Freezing applications.

The Controller performs many functions including Automatic Defrost Initiation & Full Alarm Warning. The display Fascia panel and microprocessor control board forms a single integral unit, from here to referred to as the Controller.







## 1.2 GENERAL SYSTEM OPERATION

The Controller applies proportional control of the refrigeration system components in order to maintain an integral air temperature necessary to cause rapid Chilling and Freezing.















Upon completion of the Chill or Freeze phase; determined through product temperature measurement or a programmed time period, the internal air temperature will rise and be maintained to "Hold" the product in a chilled or frozen state.

## 1.3 CONTROLLER FRONT PANEL

The controller display is made up of the following components.

-  **Sleep/Standby Button**  
Switches the Controller from the sleep mode; where seven bars are illuminated in the Display Windows ( - - - - - ), to standby mode where the unit runs.
-  **Start/Stop Button**  
Used to start and stop the Blast Chilling/Freezing Cycle.
-  **Alarm Mute Button**  
Silences the End of Cycle alarm at the end of the Chilling/Freezing Cycle.
-  **Print Button**  
A dual function button. If pressed and released the contents of the print log will be output to the printer. If pressed and held for a period of three seconds the print log is cleared – accompanied by an audible confirm (chirp).
-  **Programme Button**  
A dual function button. If pressed and released the programme will change (from A to B, B to C and C to A). If pressed and held for a period of three seconds the Controller enters the Setting Mode for a selected programme.
-  **Increment Button**  
A dual function button. Primarily used when in the User and Service programming modes to change values. Can also be used when the unit is running to show Food/Air temperature: Whilst the button is pressed in a Time Cycle or Hold Mode the temperature display will show Food Probe temperature. Whilst button is pressed in a Food Probe Cycle the temperature display show Air temperature.
-  **Manual Defrost Button**  
Used to manually start Defrost (when the unit is in Standby or Hold mode).





## 1.4 INDICATING DISPLAYS AND LED'S

-  **Time Display.**  
4 green seven segment LED's show time left to run in Timed mode, 0000 in Food Temperature mode and shows Time Elapsed in Hold mode (time since end of cycle).
-  **Temperature Display.**  
3 green seven segment LED's show Air Temperature during Timed and Hold modes via Air Probe. Shows Product Temperature in Food Probe Mode via Food Probe. (By use of Increment Button the display will show the temperature of the Probe not controlling the cycle).
-  **Food Probe Temperature LED.**  
Illuminates green during Product Cooling cycle, used in conjunction with Temperature Display.
-  **Air Temperature LED.**  
Illuminates green during Timed Cycle and Hold Cycle – used in conjunction with Time Display and Temperature Display.
-  **Hold Function LED.**  
Illuminated green to show when unit is in Hold Mode.
-  **'Hard Chill' Programme LED.**  
Illuminates green in conjunction with Programme LED's (programme A, B or C) to show that the selected programme is set as a 'Hard Chill Program'.
-  **'Soft Chill' Programme LED.**  
Illuminates green in conjunction with Programme LED's (programme A, B or C) to show that the selected programme is set as a 'Soft Chill Program'.
-  **Programme 'A'**                    Illuminated green when Programme 'A' is selected.
-  **Programme 'B'**                    Illuminated green when Programme 'B' is selected.
-  **Programme 'C'**                    Illuminated green when Programme 'C' is selected.
-  **Start/Running LED.**  
Illuminated green when the unit is in Timed/Product or Hold Modes. In conjunction with the Start/Stop Button.
-  **End of Cycle LED.**  
Illuminated red when the End of Cycle Alarm has sounded and the Mute Button has been depressed. It is extinguished when the unit is stopped by pressing the Start/Stop Button.
-  **Defrost Indication LED.**  
Illuminated red to Defrost in Operation – automatic or manual.
-  **Condensing Unit Run LED.**  
Illuminated green when Condensing Unit output is high.
-  **Evaporator Fan Run LED.**  
Illuminated green when Evaporator Fan output is high.

















**1.5 Mk4 BLAST CHILLER CONTROLLER OUTLINE OPERATING GUIDE**  
(Foster Part Number: 00-554481)



**1.5.1 Controller Operation - Basic Functions**







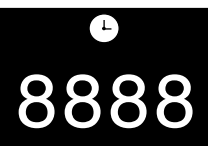

- Sleep / Standby Mode 
- Program Chill / Freeze Program Start/Stop  (Green LED illuminates during Program and Hold Modes)
- End of Cycle Alarm Mute Button  (Red LED illuminates once audible End of Cycle alarm has been muted)
- Print Data  (Press once to print data / Press and Hold for 3 seconds to clear memory).

**1.5.2 Controller Operation - User Setting Procedure**

- Change Program  (Program changes from A ⇒ B, B ⇒ C and C ⇒ A. Appropriate Program LED's illuminate)
- Change Program Parameters  (Press and Hold for 3 seconds)
  - ◆ Minutes display flashes – increment minutes value  - save parameter value. 
  - ◆ Hours display flashes – increment hours value  - save parameter value. 
  - ◆ Probe Temp. flashes\* – increment Temp. value  - save parameter value. 
  - ◆ Air Temp. flashes – increment Temp. value  - save parameter value. 
  - ◆ Hold Temp. flashes – increment Temp. value  - save parameter value. 
  - ◆ Select Hard/Soft Chill – toggle parameter value  - save parameter value. 
  - ◆ Set Print Sample Rate – increment parameter value  - save parameter value and setting mode. 
- Initiate Manual Defrost in Standby/Hold Mode  (Red LED illuminates during defrost).

\*Hours / Minutes parameter values set to 00:00

**1.5.3 Displays and Indications**

|  |  |   |  |  |
|--|--|---|--|--|
|  Compressor LED |  Time Display |  Temp. Display |  Probe Temp. LED   |  'Hard' Chill LED             |
|  Evap. Fan LED  |  |   |  Air Temp. LED     |  'Soft' Chill LED             |
|  |  |   |  Hold Function LED |  Program LED's<br>A<br>B<br>C |

## 1.6 OPERATION

- 1.6.1 In this section the behaviour of the Controller is described in the form of a list of events with regard to the system refrigeration components.  
Where outputs are stated to be in a 'high' or 'low' state, a low state indicates the board relay output contacts to be open circuit and a high state indicates the relay to be closed and hence 'live'.
- 1.6.2 **Power Connected to Unit.**  
The Controller is in a sleep mode, seven bars are displayed on the fascia panel, all outputs are in a low state ( - - - - - ).
- 1.6.3 **Sleep/Standby Button Depressed.**  
The Controller switches on, fascia panel indicates programme, time and internal air temperature. Any one of the stored programs may be selected by pressing the programme button. Programme settings may be altered by following the User Setting Procedure.
- 1.6.4 **Start/Stop Button Depressed.**  
The selected Controller programme is initiated.
- 1.6.5 **Cooling Phase.**  
If the selected programme is a Food Temperature Control programme, the following sequence of events will occur:  
The fascia panel displays Cooling Time (set to zero) and product Temperature (measured by the Food Probe).  
The refrigeration cycle begins and the Evaporator Fan output remains high throughout the cycle except if the door is opened.  
The Cooling Time displayed in the fascia panel will increment from zero.  
If internal air temperature is higher than the pre-set Air Temperature the Condensing Unit output goes high.  
When the internal air temperature pulls down to the pre-set Air Temperature the Condensing Unit output goes low.  
The Cooling Phase continues until the pre-set Product Temperature is reached.  
The end of cycle alarm sounds and the Unit enters the Hold phase (Hold LED illuminated).  
The displayed Cooling Time stops incrementing and holds the displayed value.  
The Temperature Display changes to indicate Internal Air Temperature.  
If the selected programme is a Cooling Time Control programme, the following sequence of events will occur:  
The fascia panel displays Cooling Time and Air Temperature.  
The refrigeration cycle begins and the Evaporator Fan output remains high throughout the cycle except if the door is opened.  
The Cooling Time displayed on the fascia panel will decrement from the programmed value.  
If internal air temperature is higher than the pre-set Air Temperature, the Condensing Unit output goes high.  
When the internal air temperature pulls down to the pre-set Air Temperature, the Condensing Unit output goes low.  
If the internal air temperature then rises above the pre-set Air Temperature plus the Differential, the Condensing Unit goes High.  
The Cooling time continues until the displayed time increments to zero.  
The end of cycle alarm sounds and the Unit enters the Hold phase (Hold LED illuminated).
- 1.6.6 **Hold Phase.**  
With the evaporator fan output still high, the condensing unit output falls low until the internal air temperature rises to the pre-set Hold Temperature plus the Hold Temperature Differential.  
The Condensing Unit output goes high until the internal air temperature pulls down to the pre-set Hold Temperature.  
The Hold Phase continues until the programme is stopped by operation of the Start/stop button.
- 1.6.7 **End of Cycle Alarm.**  
The Controller alarm output will go high on entry to the Hold Phase to indicate completion of the Cooling Phase.  
The Hold Alarm will stay high for the period Hold alarm Duration.  
Alternatively, the Hold Alarm may be muted by operation of the fascia Mute button.  
However the Hold LED above the Mute button will illuminate.
- 1.6.8 **Defrost Automatic or Manually Initiated.**  
The time period to the first defrost is calculated from the start of the Cooling Programme.  
If the Defrost interval is every 4 hours but the Cooling Cycle is 6 hours the Defrost will be postponed until the Unit enters Hold Mode.  
Defrosts will occur automatically in the Hold Mode. The evaporator fan output falls low.  
Depending on Defrost Type, either a Hot Gas (Type = 1) or Electric Heater (Type = 0) Defrost will be initiated and the Time Display will continue to display Time Elapsed. The temperature display will show the temperature measured by the Food Probe. The RED LED will illuminate.  
Alternatively, a Defrost can be initiated in the 'Standby' or 'Hold' modes.  
To initiate a Manual Defrost press the Defrost button once and defrost will commence.  
Defrost will be the same as in automatic mode.

## 1.7 ERROR ANNUNCIATION

Should temperature probe failure occur the controller will indicate the fault by flashing on the fascia panel: **PF1, PF2 or PF3** in the temperature display window.  
It is important to note that on Probes 1 and 2 Probe Fault occurs if a resistance corresponding to above +60°C or below -60°C. See page 13 for resistance values against temperature.

- PF1** — Indicates Food Probe failure.  
If a food probe fault occurs during a Food Temperature Control Programme the Condensing Unit output goes low.  
If a Food Probe fault occurs during a Cooling Time Programme the Controller will continue to operate normally.
- PF2** — Indicates Air Probe Failure.  
If an Air Probe fault occurs during either a Food Temperature or Cooling Time Control Programme the Condensing Unit output goes low.
- PF3** — Indicates Evaporator Coil Failure if Probe is fitted.  
A probe is not fitted, however in its place a 5.1 Kohm resistor is fitted. If this fails it will not effect the cooling cycle as the defrost will terminate using the time setting.

## 1.8 HARD OR SOFT CHILL

Hard/Soft Chilling is used to minimise surface damage to delicate products.

The Soft Chill function raises the Air Temperature during the latter part of the Cooling Phase. The Air Temperature during the Cooling Phase, while Soft Chill is selected, rises to the value of the Soft Chill Set Parameter temperature.

Under a Cooling Time Control Programme the Soft Chill level becomes active after the percentage value of the Soft Chill Set Time relative to the pre-set Cooling Time has lapsed.

Under a Food Temperature Control Programme, the Soft Chill becomes active when the Soft Chill Food Temperature, measured by the Food Probe is reached.

Soft Chilling can only be selected if the Programme Settings — Food Temperature, Cooling Air Temperature and Hold Air Temperature are set above the value of the Surface Protection Limit.

## 1.9 USER PROGRAMME SETTINGS

The following is a list of the parameters that may be adjusted by the user in the programmes A, B or C.

### 1.9.1 Cooling Time. Control Programme (Hrs : Mins).

Duration of Cooling Phase for a Cooling Time Control Programme.

If set to zero, the Controller automatically assumes a Food Temperature Control Programme.

### 1.9.2 Food temperature. Control Programme (°C).

Desired Food Temperature at completion of the Cooling Phase.

Required when a Food Temperature Control Programme is selected.

Measured by the Food Probe inserted into the product to be cooled.

### 1.9.3 Cooling Air Temperature (°C).

Counter or Cabinet internal air temperature during the Cooling Phase.

### 1.9.4 Hold Air Temperature (°C).

Counter or cabinet internal air temperature during the Hold Phase.

### 1.9.5 Cooling Type ('Hard' or 'Soft' Chill).

Selects cooling type function, which in Soft Chill raises the Air Temperature during the latter part of the Chill Phase.

Soft Chill can only be selected if the Programme Settings — Food, Chill Air & Hold Air Temperature are above the value of the Soft Chill Limit.

### 1.9.6 Printer Sample Rate.

Selects the interval between Air or Food temperature samples being recorded during the Cooling Cycle and Hold Mode.

## 1.10 PROGRAMME SETTING AND CONTROL PARAMETER ADJUSTMENT

The user can tailor the Programme Settings to suit the particular product to be cooled.

Settings can be saved in up to three programmes, stored by the controller (A, B or C).

The Controller is pre-set with three typical programmes.

### Chill Programme (P15 = 0)

|                        | ProgrammeA  | Programme B | Programme C |
|------------------------|-------------|-------------|-------------|
| Time                   | 1 Hr 30 min | 0.00 Hrs    | 1 Hr 30 min |
| Food Temperature Probe | NA          | +3°C        | NA          |
| Air Temperature Probe  | -10°C       | -10°C       | -10°C       |
| Hold Temperature       | +3°C        | +3°C        | +3°C        |
| Chill Mode             | HARD        | HARD        | SOFT        |
| Print Sample Rate      | 3           | 3           | 3           |

### Chill/Freeze and Freeze Programme (P15 = 1)

|                        | ProgrammeA | Programme B | Programme C |
|------------------------|------------|-------------|-------------|
| Time                   | 3 Hr       | 0.00 Hrs    | 1 Hr 30 min |
| Food Temperature Probe | NA         | -21°C       | NA          |
| Air Temperature Probe  | -30°C      | -30°C       | -10°C       |
| Hold Temperature       | -21°C      | -21°C       | +3°C        |
| Chill Mode             | HARD       | HARD        | SOFT        |
| Print Sample Rate      | 3          | 3           | 3           |

Control Parameters alter the characteristics of the chilling or freezing process. They should not be adjusted without a good understanding of the operation of the Controller.

If no button is pressed for a period of two minutes the controller will revert to the standby mode without saving any of the modified settings.



## 1.11 SERVICE PARAMETERS

- 1.11.1
- It is strongly advised that before adjusting any Service Parameter a thorough understanding of the Blast Chiller operating principles are obtained.
  - The Service Parameters are accessed in the following way.
  - Put the control panel into the 'Sleep' Mode.  
Press the Programme button and hold while pressing the Increment button.  
The Controller is now in the Service Parameter settings, release both buttons.
  - To save a value, press the Programme button.
  - To change a value press the Increment button till you get the desired value.
  - To exit and save the new Control Parameter values, the 'Start/Stop' button must be pressed. The controller reverts to the 'on' condition. If any other buttons are pressed the changed values will not be held.
  - If no buttons are pressed for two minutes whilst in the Service Parameter Setting Mode the controller will revert to the 'Sleep State' without saving any of the changes.

### 1.11.2 Control Parameters – Fixed or Programmable (F or P)

| No. | F or P | Description   | Settings (Limits) |
|-----|--------|---|-------------------|
| 1   | P      | <b>Cooling Temperature Differential (°C)</b><br>Cooling Set Point + Cooling Temperature Differential = High point of the cooling operation range.   | 3 (1 to 10)       |
| 2   | P      | <b>Hold Temperature Differential (°C)</b><br>Hold Set Point + Hold Temperature Differential + hold point of Hold operating range.   | 3 (1 to 10)       |
| 3   | P      | <b>Compressor Rest Time (Mins)</b><br>Minimum Time between successive compressor operations   | 0 (0 to 10)       |
| 4   | P      | <b>Defrost Termination Temperature (°C) – (NOT USED)</b><br>To be used with suitable Evaporator Temperature Probe   | 20 (0 to 50)      |
| 5   | P      | <b>Defrost Termination Time (Mins)</b><br>Maximum defrost time duration   | 6 (0 to 60)       |
| 6   | P      | <b>Number of Defrosts Per Day</b><br>Determines duration between automatic defrosts   | 6 (0 to 24)       |
| 7   | P      | <b>Defrost Type (1/0)</b><br>Hot Gas (1) or Electric (0), determines whether both the defrost and condensing unit outputs or the defrost output alone goes high when a defrost is initiated.            | 1 (0 to 1)        |
| 8   | P      | <b>Drain Down Time (Mins)</b><br>Time period after defrost for which the Defrost and Condensing Unit outputs remain low.  | 5 (0 to 24)       |
| 9   | P      | <b>Fan Delay Time (Mins)</b><br>Time period after Drain Down Time for which Evaporator Fan output remains low.  | 1 (0 to 20)       |
| 10  | P      | <b>Fan Delay Temperature (°C) – (NOT USED)</b><br>To be used with suitable Evaporator Temperature Probe.  | 0 (-20 to 20)     |
| 11  | P      | <b>Cabinet Identification Number</b><br>Used to set the number printed out at the head of the Print Log to identify the Controller/Cabinet.   | 1 (0 to 255)      |
| 12  | P      | <b>Print Out Language</b><br>Determines the Language Printed when Downloading the Print Log.<br>(0= English, 1=Danish, 2=Dutch, 3=French, 4=German, 5=Italian, 6=Spanish, 7=Swedish).                   | 0 (0 to 7)        |
| 13  | P      | <b>Hold Alarm Duration (Mins)</b><br>Maximum Duration of Hold Alarm.  | 2 (0 to 99)       |
| 14  | P      | <b>Display Offset</b><br>Allows the display temperature to be adjusted up or down to allow for system tolerances.   | 0 (-15 to 15)     |
| 15  | P      | <b>Chill/Freeze Select (1/0)</b><br>Chill (0) or Freeze (1) Configures operation as a Chiller or Freezer  | 0 (0 to 1)        |
| 16  | F      | <b>Maximum Chill Cooling Set Point (°C)</b><br>Maximum allowable Chill Temperature Set Point Active when Chiller Operation is selected<br>(parameter 15=0)  | 10                |
| 17  | F      | <b>Minimum Chill Cooling Set Point (°C)</b><br>Minimum allowable Chill Temperature Set Point Active when Chiller Operation is selected<br>(parameter 15=0)  | -15               |
| 18  | F      | <b>Maximum Freeze Cooling Set Point (°C)</b><br>Maximum allowable Freeze Temperature Set Point Active when Freeze Operation is selected<br>(parameter 15=1)   | 10                |
| 19  | F      | <b>Minimum Freeze Cooling Set Point (°C)</b><br>Minimum allowable Freeze Temperature Set Point<br>Active when Freeze Operation is selected (parameter 15=1)   | -35               |
| 20  | P      | <b>'Soft' Chill Temperature (°C)</b><br>'Soft' Chill Air Temperature Set point during Cooling Phase when 'Soft' Chill is active.  | -2 (-25 to 5)     |
| 21  | P      | <b>'Soft' Chill Time (%)</b><br>Under a Cooling Time Control Program the percentage of Cooling Time after which the Air Temperature Set Point rises to the value 'Soft' Chill Temperature.              | 70 (0 to 100)     |
| 22  | P      | <b>'Soft' Chill Food Temperature (°C)</b><br>Under a Food Temperature Control Program the measured Food Temperature at which the Air Temperature Set Point rises to the value 'Soft' Chill Temperature. | 5 (-10 to +30)    |

|    |   |  |                  |
|----|---|--|------------------|
| 23 | P | <b>'Soft' Chill Limit (°C)</b><br>If the programmed Food Temperature (under a Food Temperature Control Programme) is above the Air Temperature or Hold Temperature the 'Soft' Chill function cannot be selected. | -15 (+5 to -15)  |
| 24 | P | <b>Graph Print Out Low Point</b>   | -10 (-30 to +30) |
| 25 | P | <b>Year</b>  | 00 (00 to 99)    |
| 26 | P | <b>Months</b>  | 01 (01 to 12)    |
| 27 | P | <b>Date</b>  | 01 (01 to 31)    |
| 28 | P | <b>Time – Hours</b>  | 00 (00 to 23)    |
| 29 | P | <b>Time – Minutes</b>  | 00 (00 to 59)    |

1.11.3 **Service Parameters – Additional Information.**

- **Display Offset (P14)**  
Allows the display temperature (and hence operating temperature) to be adjusted up or down to allow for systems tolerances. This provides a higher level of temperature accuracy.
- **Graph Print Out Low Point.**  
The service graph print out has a range of 60°C. This parameter sets a low point of the graph (example of P24 is set to -10°C the graph will show the temperature/time between +50°C to -10°C). The graph function is intended to assist the Service Operation Settings and testing.
- **Date/Time Settings (P25/P26/P27/P28/P29).**  
These values are used in the Real Time Clock (RTC), the times and dates are printed with temperature data from the print log. under normal circumstances the controller will be pre-programmed with the correct Time and Date (GMT or BST). No account is taken for international time zones; therefore some adjustments may be necessary. The controller is fitted with a PCB battery, which will retain time date setting if the electrical supply is removed/isolated once set.

**1.12 CONTROLLER MODEL SELECTION**

1.12.1 The controller holds the Standard Operating Settings for 16 (0 to 15 inclusive) Blast Chiller and Blast Freezer models (both integral and remote). To select the appropriate models Bit Switches are used. The Bit Switches are a series of 4, two position switches (see below) situated on the back of the controller PCB and which can be accessed with the rear cover removed.

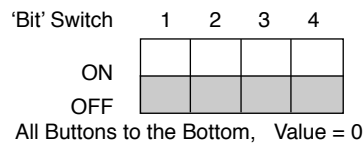

1.12.2 Using binary Notation – values between 0 and 15 can be obtained. The Bit pattern settings to access these are as follows:

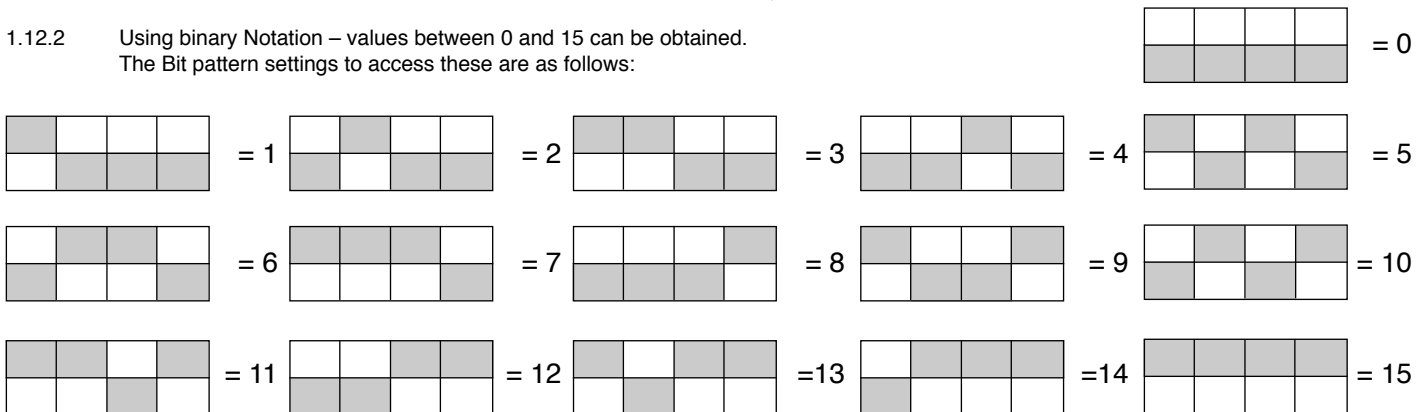

- 1.12.3 By setting the bit switches to the appropriate positions various Operating Parameters are selected.
- If setting 12 - 15 inclusive are selected the unit will not function as these are not currently pre-programmed.
  - A full breakdown of the Pre-set Values is shown on the next page.
  - Should any programme need to be changed the User Programme Setting Procedure on page 7 must be followed.
  - Should any parameters require changing the Service Parameter Setting Procedure on pages 10 & 11 must be followed.

### 1.12.4 Controller Model Selection Table

| Denomination        |                                       | BC  | BF  | BC/F | FBC | FBF | FBC/<br>F | BC<br>(R) | BF<br>(R) | BC/F<br>(R) | FBC<br>(R) | FBF<br>(R) | FBC/<br>F(R) | These settings<br>are not used |    |    |    |
|---------------------|---------------------------------------|-----|-----|------|-----|-----|-----------|-----------|-----------|-------------|------------|------------|--------------|--------------------------------|----|----|----|
| BIT Switch Settings |                                       | 0   | 1   | 2    | 3   | 4   | 5         | 6         | 7         | 8           | 9          | 10         | 11           | 12                             | 13 | 14 | 15 |
| P1                  | Cooling Temperature Differential (°C) | 3   | 3   | 3    | 3   | 3   | 3         | 3         | 3         | 3           | 3          | 3          | 3            |                                |    |    |    |
| P2                  | Hold Temperature Differential (°C)    | 3   | 3   | 3    | 3   | 3   | 3         | 3         | 3         | 3           | 3          | 3          | 3            |                                |    |    |    |
| P3                  | Compressor Rest Time (mins)           | 0   | 0   | 0    | 0   | 0   | 0         | 0         | 0         | 0           | 0          | 0          | 0            |                                |    |    |    |
| P4                  | Defrost Termination Temperature (°C)  | 20  | 20  | 20   | 20  | 20  | 20        | 20        | 20        | 20          | 20         | 20         | 20           |                                |    |    |    |
| P5                  | Defrost Termination Time (mins)       | 6   | 6   | 6    | 6   | 6   | 6         | 12        | 12        | 12          | 12         | 12         | 12           |                                |    |    |    |
| P6                  | Number of Defrosts (per day)          | 6   | 6   | 6    | 6   | 6   | 6         | 6         | 6         | 6           | 6          | 6          | 6            |                                |    |    |    |
| P7                  | Defrost Type (0=elec/ 1=hot gas)      | 1   | 1   | 1    | 1   | 1   | 1         | 0         | 0         | 0           | 0          | 0          | 0            |                                |    |    |    |
| P8                  | Drain Down Time (mins)                | 5   | 5   | 5    | 5   | 5   | 5         | 5         | 5         | 5           | 5          | 5          | 5            |                                |    |    |    |
| P9                  | Fan Delay Time (mins)                 | 1   | 1   | 1    | 1   | 1   | 1         | 1         | 1         | 1           | 1          | 1          | 1            |                                |    |    |    |
| P10                 | Fan Delay Temperature (°C)            | 0   | 0   | 0    | 0   | 0   | 0         | 0         | 0         | 0           | 0          | 0          | 0            |                                |    |    |    |
| P11                 | Cabinet ID Number                     | 1   | 1   | 1    | 1   | 1   | 1         | 1         | 1         | 1           | 1          | 1          | 1            |                                |    |    |    |
| P12                 | Print Out Language                    | 0   | 0   | 0    | 3   | 3   | 3         | 0         | 0         | 0           | 3          | 3          | 3            |                                |    |    |    |
| P13                 | Hold Alarm Duration (mins)            | 2   | 2   | 2    | 2   | 2   | 2         | 2         | 2         | 2           | 2          | 2          | 2            |                                |    |    |    |
| P14                 | Display Offset                        | 0   | 0   | 0    | 0   | 0   | 0         | 0         | 0         | 0           | 0          | 0          | 0            |                                |    |    |    |
| P15                 | Chill (0) / Freeze (1) Select         | 0   | 1   | 1    | 0   | 1   | 1         | 0         | 1         | 1           | 0          | 1          | 1            |                                |    |    |    |
| P16                 | Max. Chill Cooling Set Point (°C)     | 10  | 10  | 10   | 10  | 10  | 10        | 10        | 10        | 10          | 10         | 10         | 10           |                                |    |    |    |
| P17                 | Min. Chill Cooling Set Point (°C)     | -15 | -15 | -15  | -15 | -15 | -15       | -15       | -15       | -15         | -15        | -15        | -15          |                                |    |    |    |
| P18                 | Max. Freeze Cooling Set Point (°C)    | 10  | 10  | 10   | 10  | 10  | 10        | 10        | 10        | 10          | 10         | 10         | 10           |                                |    |    |    |
| P19                 | Min. Freeze Cooling Set Point (°C)    | -35 | -35 | -35  | -35 | -35 | -35       | -35       | -35       | -35         | -35        | -35        | -35          |                                |    |    |    |
| P20                 | Soft Chill Temperature (°C)           | -2  | -2  | -2   | -2  | -2  | -2        | -2        | -2        | -2          | -2         | -2         | -2           |                                |    |    |    |
| P21                 | Soft Chill Time (%)                   | 70  | 70  | 70   | 70  | 70  | 70        | 70        | 70        | 70          | 70         | 70         | 70           |                                |    |    |    |
| P22                 | Soft Chill Food Temperature (°C)      | 5   | 5   | 5    | 5   | 5   | 5         | 5         | 5         | 5           | 5          | 5          | 5            |                                |    |    |    |
| P23                 | Soft Chill Limit (°C)                 | -15 | -15 | -15  | -15 | -15 | -15       | -15       | -15       | -15         | -15        | -15        | -15          |                                |    |    |    |
| P24                 | Graph Print Out Low Point             | -10 | -10 | -10  | -10 | -10 | -10       | -10       | -10       | -10         | -10        | -10        | -10          |                                |    |    |    |
| P25                 | Year                                  | 00  | 00  | 00   | 00  | 00  | 00        | 00        | 00        | 00          | 00         | 00         | 00           |                                |    |    |    |
| P26                 | Month                                 | 01  | 01  | 01   | 01  | 01  | 01        | 01        | 01        | 01          | 01         | 01         | 01           |                                |    |    |    |
| P27                 | Date                                  | 01  | 01  | 01   | 01  | 01  | 01        | 01        | 01        | 01          | 01         | 01         | 01           |                                |    |    |    |
| P28                 | Hours                                 | 00  | 00  | 00   | 00  | 00  | 00        | 00        | 00        | 00          | 00         | 00         | 00           |                                |    |    |    |
| P29                 | Minutes                               | 00  | 00  | 00   | 00  | 00  | 00        | 00        | 00        | 00          | 00         | 00         | 00           |                                |    |    |    |

## 1.13 ELECTRICAL CONNECTIONS

|        |   |   |   |                          |
|--------|---|---|---|--------------------------|
| 1.13.1 | <b>Ratings</b><br>Nominal Supply Voltage:<br>Supply Range:<br>Humidity  | 230Va.c. +/-10%<br>198-254Va.c.<br>80%  | Supply Frequency:<br>Temperature Range: | 50 / 60 Hz<br>0 to +70°C |
| 1.13.2 | <b>Mains Services</b><br>Mains Supply:<br>Compressor / Solenoid Valve:<br>Evaporator Fans:<br>Defrost:<br>Alarm:<br>Common Neutral: | 1 Live (L1), 1 Neutral (N1), 1 Earth (E).<br>1 Switched Live (C).<br>2 Switched Live (F).<br>2 Switched Live (D).<br>1 Switched Live (A).<br>5 Neutral (N). |   |                          |
| 1.13.3 | <b>Sensors</b><br>Food Probe:<br>Air Probe:<br>Resistor 5.1Kohm:<br>Door Switch:<br>Printer Connection:                             | 2 Screw Terminals (PRB1).<br>2 Screw Terminals (PRB2).<br>2 Screw Terminals (PRB3).<br>2 Screw Terminals (DS).<br>Plug In Connection.                       |   |                          |

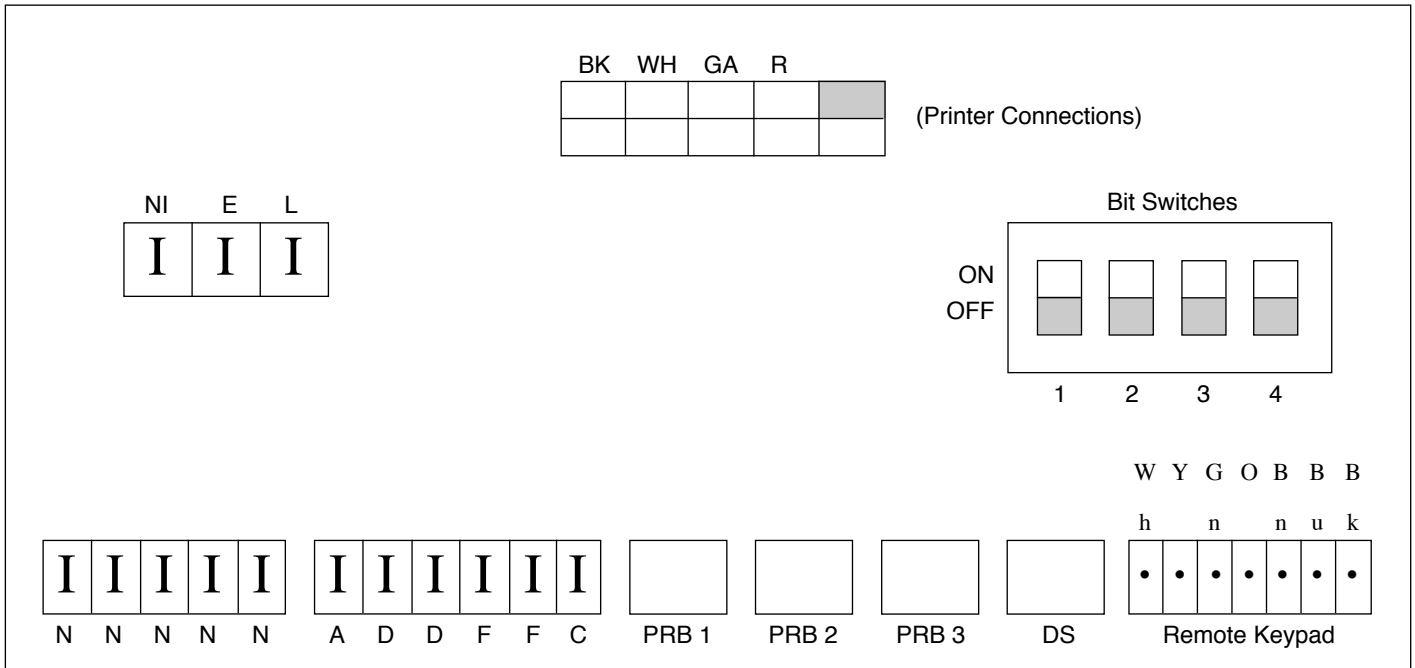

## 1.14 RESISTANCE VALUES:

The following table relates to resistance values against temperature.

|       |           |       |           |       |             |
|-------|-----------|-------|-----------|-------|-------------|
| +60°C | 656 ohms  | +10°C | 3448 ohms | -20°C | 12100 ohms  |
| +30°C | 1679 ohms | 0     | 5107 ohms | -30°C | 19455 ohms  |
| +20°C | 2381 ohms | -10°C | 7754 ohms | -60°C | 100181 ohms |

# **SECTION 2**

## **Cabinet & Counter**

### **BLAST CHILLERS & FREEZERS**



## 2. OPERATING INSTRUCTIONS FOR THE Mk3 MICROPROCESSOR UP TO MAY 2000

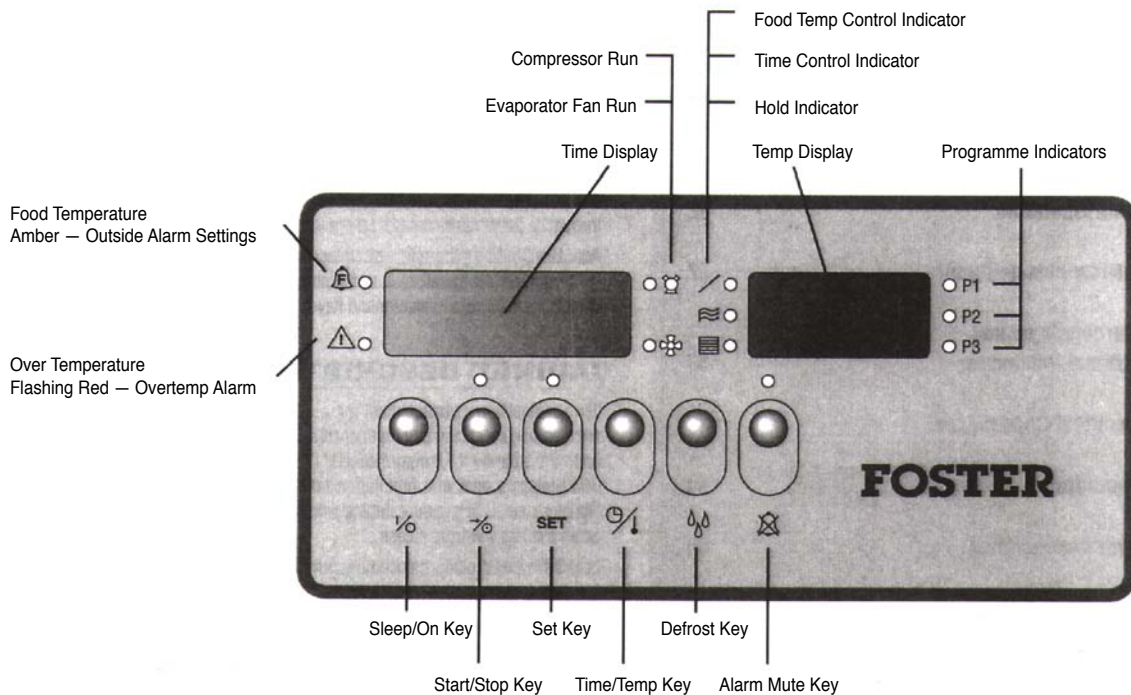

Figure 1 Controller Front Panel — Product Code F15247077

### 2.1 DISPLAY FASCIA PANEL

2.1.1 **Construction** – Fitting of the fascia panel to the Counter or Cabinet sheet metal unit cover is by means of a screw and boss fixing.

2.1.2 **Ratings** – An 'O' ring provides sealing between the Counter/Cabinet unit cover and fascia panel. The front of the fascia panel has protection classification of IP54 and the material used is fire retardant and self extinguishing.

2.1.3 **Symbols and Indicators** – The displays on the fascia panel consist of a smoked seven digit seven segment display together with the following indicators and symbols.

2.1.4 **Illuminated Indicators** – These appear to the three digit seven segment display.

- **Condensing Unit** – LED illuminated green when Condensing Unit outputs high.
- **Evaporator Fans** – LED illuminated green when Evaporator Fan output is high.
- **Food Temperature** – LED illuminated amber when Calculated Stored Product Temp. is outside the preset High and Low Food Temperature Alarm settings (11 and 12 respectively).
- **Overtemperature** – LED flashing red in the event of the Counter/Cabinet Alarm internal temperature exceeding the present Overtemperature Alarm Setting (14).
- **Food Control Cooling** – LED illuminated green prior to and during the Cooling Phase of a Food Temperature Control programme.
- **Time Control Cooling** – LED illuminated green prior to and during the Cooling Phase of a Cooling Time Control programme.
- **Hold** – LED illuminated green during the Hold Phase.
- **Programme 1** – P1, LED illuminated green when Programme 1 is selected.
- **Programme 2** – P2, LED illuminated green when Programme 2 is selected.
- **Programme 3** – P3, LED illuminated green when Programme 3 is selected.
- **Run** – LED illuminated green during programme operation.
- **Programming** – LED illuminated green during programming procedure.
- **Hold Alarm** – LED illuminated green after Hold Alarm is muted.

#### 2.1.5 Key Symbols

- Switches the controller between 'sleep' and 'on' states.
- Starts or stops a selected controller programme.
- **SET** Used to enter programming sequence and acknowledge programme settings.
- Used to alter time or temperature values during programming sequence.
- Used in conjunction with the Key to initiate a manual defrost.
- Will mute the audible Hold Alarm permanently or the Food Temperature Alarm for a period of ten minutes.

## 2.2 SURROUNDINGS AND EXTERNAL INFLUENCES

### 2.2.1 INPUTS

- **Food Temp. Probe** – Senses counter/cabinet product temperature. Negative temperature/resistance coefficient thermistor probe.
- **Air Temp. Probe** – Senses counter/cabinet internal air temperature. Negative temperature/resistance coefficient thermistor probe.
- **Evap. Temp. Probe** – Senses temperature at the evaporator coil, required to terminate defrost. No longer fitted on models produced after September 1998, replaced by 5.1Kohm resistor. Defrost terminates on time only.
- **Safety probe** – Senses temperature adjacent to the evaporator coil in order to detect a internal overtemperature. No longer fitted on models produced after July 1998, replaced by 56Kohm resistor.
- **Door Switch** – Voltage free contacts, open circuit when door is open causing evaporator fan output to fall low and condensing unit output to fall low after a period of one minute.
- **Display Fascia** – Used to switch On/Off the controller. Initiate or terminate a chill or freeze programme. Programme in operating parameters. Manually initiate a defrost. Cancel all alarm outputs.

### 2.2.2 OUTPUTS

- **Condensing Unit** – Relay output switching single phase mains supply to condensing unit (compressor and condensor fan). Contact rating 250Vac 10A.
- **Evaporator Fan** – Relay output switching single phase mains supply to evaporator fan. Also, in parallel with the evaporator fan are connected the mullion and vaporiser tray heaters. Contact rating 250Vac 10A.
- **Defrost** – Relay output switching single phase mains supply to Hot gas solenoid or Electric heaters. Contact rating 250Vac 10A.
- **External Alarm** – Relay output switching single phase mains supply to alarm, activated when chill phase is completed, when calculated food temperature is outside preset limits (during hold phase) and in the event of an internal overtemperature. Contact rating 250Vac 10A.
- **Display Fascia** – Seven segment display, seven digets. Normally indicating cabinet air or product temperature and cooling time. To display parameter values during controller programming. Status indication during defrost. Indicator LED's representing correct control phase, selected programme and status of refrigeration component outputs

## 2.3 ELECTRICAL CONNECTIONS

For connections to rear of controllers. See Figure 2 below.

- **Supply** – 1 Live (L1), 1 Neutral (N1), 1 Earth (E)
- **Condenser** – 1 Live (C)
- **Evaporator Fans** – 2 Live (F)
- **Defrost** – 2 Live (D)
- **Alarm** – 1 Live (AL)
- **Common Neutral** – 5 Neutral (N)
- **Food Probe** – 2 Screw Terminals (PRB1)
- **Air Probe** – 2 Screw Terminals (PRB2)
- **Evaporator Probe** – 2 Screw Terminals (PRB3)
- **Safety Probe** – 2 Screw Terminals (PRB4)
- **Door Switch** – 2 Screw Terminals (DOORSW)

Figure 2 Connections to rear of controller

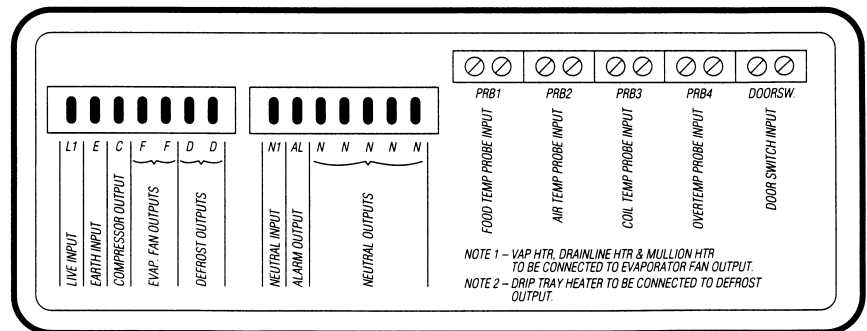

## 2.4 OPERATION

In this section the behaviour of the controller is described in the form of a list of events (event/response list) with regard to the counter/cabinet refrigeration components.

Where outputs are stated to be in a 'high' or 'low' state, a low state indicates controller board relay output contacts to be open and a high state indicates the relay contacts to be closed.

### 2.4.1 Refrigeration and Defrost.

2.4.2 **Power Connected to Counter or Cabinet** – The controller is in a 'sleep' mode, seven bars are displayed on the fascia panel, all outputs are in a low state.

2.4.3 **Key Depressed** – The controller switches on, fascia panel indicates programme time and internal air temperature. Any one of three stored programmes may be selected. Programme settings may also be altered.

2.4.4 **Key Depressed** – The selected controller programme is initiated.

2.4.5 **Cooling Phase** – If the selected programme is a Food Temperature Control Programme, the following sequence of events will occur – (**See list of Control Parameters, section 6.3**).

The fascia panel displays Cooling Time (set to zero) and Food Temp. (measured by Food Probe).

The refrigeration cycle begins and the Evaporator output remains high throughout the cycle. The Cooling Time displayed in the fascia panel will increment from zero. If internal air temp. is higher than the preset Air Temperature Differential (1) the Condensing Unit output goes high.

When the internal air temperature pulls down to the preset Air Temperature, the Condensing Unit output goes low. This Cooling Phase continues until the preset Foot Temperature is reached. The displayed Cooling Time stops incrementing and holds the displayed value (duration of Cooling Phase).

Or if the selected programme is a Cooling Time Control Programme, the following sequence of events occurs.

The fascia panel displays Cooling Time and Air Temperature. The refrigeration cycle begins and the Evaporator output remains high throughout the cycle. The Cooling Time displayed on the fascia panel will increment from zero. The Cooling Time displayed on the fascia panel will decrement from the programmed value. If internal air temperature is higher than the preset Air Temperature plus Cooling Temperature Differential (1) the Condensing Unit output goes high. When the internal air temperature pulls down to the preset Air Temperature, the Condensing Unit output goes low. This Cooling Phase continues until the displayed time decrements to zero.

2.4.6 **Hold Phase** – The Hold alarm output goes high to indicate completion of the Cooling Phase. With the evaporator fan output still high, the condensing unit output falls low until the Cabinet or Counter internal air temperature rises to the preset Hold Temperature plus Hold Temperature Differential (2). The Condensing unit output goes high until the internal air temperature pulls down to the preset Hold Temperature. The Hold Phase continues until the programme is stopped by operation of the start/stop key.

2.4.7 **Time Period Elapsed Between Automatic Defrost or Manually Initiated Defrost**– The time period to the first defrost is calculated from the beginning of the cycle.

The evaporator fan output falls low, depending on parameter Defrost Type (7), either a Hot Gas (Defrost Type = 1) or Electric Heater (Defrost Type = 0) defrost will be initiated and **dEF** will be displayed on the fascia panel.

- **Hot Gas** – Defrost output goes high (operating a solenoid valve) and Condensing Unit output goes high.
- **Electric** – Defrost output goes high (operating an electric heater) and Condensing Unit output goes low.
- When Defrost Termination Temperature (4) is reached or, Defrost Termination Time (5) has elapsed, the Defrost and Condensing Unit outputs goes low for the Drain Down Period (8).
- The fascia panel will now display **REC** and the refrigeration cycle restarts, however the Evaporator Fan output will not go high until the Fan Delay Period (9) has elapsed or the Fan Delay Temperature (10) has been reached. (Terminates on time if 5.1 kohm resistor is fitted)
- During the defrost and recovery periods, the evaporator coil temperature measured by the Evaporator Probe may be viewed by pressing the  $\odot/\downarrow$  key. The refrigeration cycle will now recommence with internal air temperature displayed on the fascia.

2.4.8 **Alarm Functions** – The Food temperature and Hold alarms may be cancelled by operation of the fascia panel alarm mute button. The internal overtemperature alarm can only be cancelled by removing power from the controller.

- **Hold Alarm** – The controller alarm output will go high on entry to the Hold Phase to indicate completion of the Cooling Phase. The Hold Alarm Duration (13). Alternatively, the Hold Alarm may be permanently muted by operation of the fascia panel  $\boxtimes$  key.
- **Food Temperature** – The controller will calculate the temperature of the stored product during the Hold Phase through monitoring internal air temperature. Should the calculated stored product temperature fall outside the parameters High Food Temperature Alarm and Low Food Temperature Alarm (11 and 12 respectively), the Food Temperature LED will illuminate amber and the alarm output will go high. Should the stored product temperature fall back within the High and Low Food Temperature Alarm parameters the Food Temperature LED will extinguish and the alarm output will return to a low state. The Food Temperature Alarm (if in a high state) may be temporarily cancelled by operation of the fascia panel  $\boxtimes$  key. This will cause the alarm output to fall low for a period of ten minutes. If after the ten minute period, the calculated Food Temperature is still outside the preset High and Low Food Temperature Alarm Settings, the alarm output will return to a high state.
- **Internal Overtemperature Alarm** – Should the internal temperature rise above the parameter. Overtemperature Alarm setting (14), possibly due to a defrost heater malfunction, the Overtemperature Alarm LED will flash red and the alarm output will go high. Also at this point, all other outputs will fall low (condensing unit, evaporator fan motors and defrost). The controller will remain in an Overtemperature Alarm state until the cause is removed i.e. until the internal temperature falls below the parameter. Overtemperature Alarm Setting (14) or power is disconnected from the controller. No longer applies to models fitted with the 56Kohm resistor.

2.4.9 **Programme Settings**

- **Cooling Time (Mins)** – Duration of Cooling Phase for a Cooling Time Control Programme. If set to zero, the controller automatically assumes a Food Temperature Control Programme.
- **Food Temperature (°C)** – Desired Food Temperature at completion of the Cooling Phase. Required when a Food Temperature Control Programme is selected. Measured by the Food Probe inserted into the product to be cooled.
- **Cooling Air Temp. (°C)** – Counter or Cabinet internal air temperature during the Cooling Phase.
- **Hold Air Temp. (°C)** – Counter or Cabinet internal air temperature during the Hold Phase.
- **Surface Protection (On/Off)** – Selects Surface Protection function which raises the Air Temperature during the latter part of the Chill Phase. Surface Protection can only be selected if the Programme Settings - Food, Chill, Air and Hold Air Temperature are above the value Surface Protection Limit (23).

## 2.5 ERROR ANNUNCIATION

Should a temperature probe failure occur the controller will indicate the fault by flashing on the fascia panel: **PF1, PF2, PF3 or PF4**.

- **PF1** – If a food probe fault occurs during a Food Temperature Control programme, the Condensing Unit Output will fall low. If a food probe fault occurs during a Cooling Time Control programme, the Controller will continue to operate normally.
- **PF2** – If an air probe fault occurs during either a Food Temperature or Cooling Time Control Programme the condensing unit output will fall low.
- **PF3** – If an evaporator probe fault occurs, the parameter Defrost Termination Temperature (4) is ignored and defrosts are caused to terminate only after the period Defrost Termination Time (5) has elapsed. No longer applies to models fitted with the 5.1Kohm resistor, defrost is terminated by time only.
- **PF4** – If a safety fault occurs, all controller outputs will fall low. (The overtemperature alarm will not sound). No longer applies to models fitted with the 56 Kohm resistor.

2.5.1 **Additional Features.**

2.5.2 **Surface Protection** – To minimise surface damage to delicate products, the Surface Protection function raises the Air Temperature during the latter part of the Cooling Phase.

The Air Temperature during the Cooling Phase while Surface Protection is active, rises to the value of Surface Protection Temperature (20).

Under a Cooling Time Control Programme, Surface Protection Time (21) of the preset Cooling Time has elapsed.

Under a Food Temperature Control Programme, Surface Protection becomes active when the value Surface Protection Food Temperature (22), measured by the Food Probe is reached.

Surface Protection can only be selected if the Programme Settings – Food Temperature, Cooling Air Temperature and Hold Air Temperature are above the value Surface Protection Limit (23).

2.5.3 **Cooling Programme Extension** – During the Hold Phase following a Cooling Time Control Programme, the controller can be caused to re-enter the Cooling Phase for a further ten minutes. Programme Extension can be initiated by holding down the SET key and pressing the  $\odot/\downarrow$  key.







2.5.4 **Self Test Function** – It is possible to cause the controller to enter a test routine during which the display outputs, relay outputs, inputs, software and software version may be checked. With power disconnected from the counter or cabinet, a jumper must be connected across the 2 'Test Pins', positioned adjacent to the 'Door Switch' screw terminal input of the controller printed circuit board. All four temperature probes (food, air, evaporator and safety) and the door switch must be disconnected from the controller. When power is re-connected to the counter or cabinet and the controller is switched on, the test routine will be initiated. On the display fascia panel, each segment of the display and each LED indicator will illuminate in turn. Any faulty display output can be identified during this test routine.

2.5.5 Pressing the fascia panel keys will perform the tests detailed below. Note, the display will illuminate randomly during these tests (unless stated otherwise).

- If the  $\odot$  key on the fascia panel is pressed **r1** will be displayed in the right hand window of the display fascia panel and Defrost Output will go high.
- If the  $\odot/\downarrow$  key on the fascia panel is pressed **r2** will be displayed in the right hand window of the display fascia panel and the Evaporator Fan Output will go high.
- If the **'SET'** key on the fascia panel is pressed, one of the following codes will be displayed in the right hand window of the display fascia panel.



|     |                       |
|-----|-----------------------|
| PAS | Self Tests Passed     |
| FL1 | Food Probe Fail       |
| FL2 | Air Probe Fail        |
| FL3 | Evaporator Probe Fail |
| FL4 | Safety Probe Fail     |
| FL5 | Software Fail         |

- If the  key on the fascia panel is pressed, the Software Version and Issue, e.g. CDO will be displayed in the right hand window of the display fascia panel.
- If the  key on the fascia panel is pressed, r3 will be displayed in the right hand window of the display fascia panel and the Condensing Unit Output will go high.
- If the  key on the fascia panel is pressed, r4 will be displayed in the right hand window of the display fascia panel and the Alarm Output will go high.
- To exit the test routine power must be disconnected from the Counter or Cabinet and the jumper removed from the 'Test Pins' on the controller printed circuit board.
- If the  key on the fascia panel is pressed, the Software Version and Issue, e.g. CDO will be displayed in the right hand window of the display fascia panel.
- If the  key on the fascia panel is pressed, r3 will be displayed in the right hand window of the display fascia panel and the Condensing Unit Output will go high.
- If the  key on the fascia panel is pressed, r4 will be displayed in the right hand window of the display fascia panel and the Alarm Output will go high.
- To exit the test routine power must be disconnected from the Counter or Cabinet and the jumper removed from the 'Test Pins' on the controller printed circuit board.

## 2.6 PROGRAMME SETTING AND CONTROL PARAMETER ADJUSTMENT

Table 2 – Programme Settings

The user can tailor the Programme Settings to suit the particular product to be cooled. Settings can be saved in up to three programmes, stored by the controller (P1, P2 and P3). The controller is preset with three typical Chill programmes.

| Chill Programme P15 = 0        |             |             |             |
|--------------------------------|-------------|-------------|-------------|
|                                | Programme 1 | Programme 2 | Programme 3 |
| Time                           | 1Hr 30min   | 0.00 Hrs    | 1Hr 30min   |
| Probe Temp                     | NA          | +3°C        | NA          |
| Air Temp                       | -10°C       | -10°C       | -10°C       |
| Hold Temp                      | +3°C        | +3°C        | +3°C        |
| SP                             | OFF         | OFF         | ON          |
| Chill/Freeze Programme P15 = 1 |             |             |             |
|                                | Programme 1 | Programme 2 | Programme 3 |
| Time                           | 3Hr         | 0.00 Hrs    | 1Hr 30min   |
| Probe Temp                     | NA          | -21°C       | NA          |
| Air Temp                       | -30°C       | -30°C       | -10°C       |
| Hold Temp                      | -21°C       | -21°C       | +3°C        |
| SP                             | OFF         | OFF         | ON          |

Control Parameters alter the characteristics of the chilling and freezing control process. The Control parameters should not be adjusted without detailed knowledge of the operation of the controller.

During the programming of either Programme Settings or Control Parameters, if no key is pressed for a period of two minutes, the controller will exit the particular programming mode without saving any modified settings or parameters.

2.6.1 **Programme Setting** – While the controller is switched on with Cooling Time and Food Temperature or Air Temperature displayed on the fascia panel, the required stored programme can be selected. While holding down the 'SET' key, pressing the 'Time/Temp' key will change the selected programme, indicated by the green LEDs P1, P2 or P3.

- To enter the programming sequence the 'SET' key must be depressed for five seconds, until the green programming LED is illuminated. The Cooling Time minutes display will flash and the minutes value may be altered using the 'Time/Temp' key.
- Pressing the 'SET' key again will cause the Cooling Time hours display to flash, which may be altered using 'Time/Temp' key.
- Food Temperature Control Programme (Cooling Time set to zero) – Pressing the 'SET' key will cause the green Food Control Cooling LED to illuminate and the Food temperature may be altered using the 'Time/Temp' key. Pressing the 'SET' key again causes the green Air Control Cooling LED to illuminate and the Air Temperature may be altered using the 'Time/Temp' key.
- Cooling Time Control Programme (Cooling Time set above zero) – Pressing the 'SET' key will cause the green Air Control LED to illuminate and the Air Temperature may be altered using the 'Time/Temp' key.
- Pressing again the 'SET' key will cause the green Hold LED to illuminate and the Hold Temperature may be altered using the 'Time/Temp' key.
- Pressing again the 'SET' key will cause SP (Surface Protection) to be displayed in the left hand window of the fascia panel. Surface Protection can be selected using the 'Time/Temp' key and On or Off is displayed in the right hand window of the fascia panel display.
- Pressing again the 'SET' key will save the programme settings and the fascia panel display will flash for five seconds (indicating storage of programme settings). The green Programming LED will extinguish and the controller will exit the programming sequence.

2.6.2 **Control Parameters** – Are accessed while the controller is in the 'sleep' state with seven bars displayed in the fascia panel. While holding down the 'SET' key, pressing the  key will cause the fascia panel to display the Control Parameter number in the left hand window and the Control Parameter value in the right hand window. The value may be altered (within its limits) by operation if the 'Time/Temp' key. Pressing the 'SET' key causes the display to advance to the next Control Parameter.

- To exit and save the new Control Parameter values, the 'Start/Stop' key must be pressed. The controller reverts to the 'on' state.
- To exit without saving the new Control Parameter values, the  key must be pressed. The controller reverts to the 'sleep' state.

| No. | F or P | Description   | Setting (Limits) |
|-----|--------|---|------------------|
| 1   | P      | <b>Cooling temperature Differential (°C)</b><br>Cooling Set Point + Cooling Temp.<br>Differential = High point of Cooling operating range.  | 3 (1 to 10)      |
| 2   | P      | <b>Hold Temperature Differential (°C)</b><br>Hold Set Point + Hold Temp.<br>Differential = Hold point of Hold operating range.  | 3 (1 to 10)      |
| 3   | P      | <b>Compressor Rest Time (Mins)</b><br>Minimum Time between successive compressor operations.  | 0 (0 to 10)      |
| 4   | P      | <b>Defrost Termination Temp. (°C)</b><br>Evaporator probe temperature at which defrost terminates.<br>Not used if 5.1Kohm Resistor fitted.  | 20 (0 to +50)    |
| 5   | P      | <b>Defrost Termination Time (Mins)</b><br>Maximum defrost time duration   | 8 (0 to 60)      |
| 6   | P      | <b>Number of Defrosts per Day</b><br>Determines duration between automatic defrosts.  | 6 (0 to 24)      |
| 7   | P      | <b>Defrost Type (1/0)</b><br>Hot Gas (1) or Electric (0), determines whether both the defrost and condensing unit outputs it the defrost output alone goes high when a defrost is initiated.  | 1 (0 to 1)       |
| 8   | P      | <b>Drain Down Time (mins)</b><br>Time period after defrost for which the Defrost and Condensing unit outputs remain low.  | 5 (0 to 24)      |
| 9   | P      | <b>Fan Delay Time (Mins)</b><br>After drain down period, time for which Evaporator Fan output remains low.  | 1 (0 to 20)      |
| 10  | P      | <b>Fan delay Temperature (°C)</b><br>After drain down period, Evaporator Fan output remains low until the Fan Delay Temperature measured by the evaporator probe is reached. No longer applies to models fitted with the 5.1Kohm resistor, Fan Delay is by time only. | 0 (-20 to +20)   |
| 11  | P      | <b>High Food Temperature Alarm (°C)</b><br>Value to be added to High Point of Hold Operating Range (Hold Set Point plus hold Differential).   | 5 (1 to 20)      |
| 12  | P      | <b>Low Food Temperature Alarm (°C)</b><br>Value to be subtracted from Low Point of Hold Operating Range (Hold Set Point).   | 5 (1 to 20)      |
| 13  | P      | <b>Hold Alarm Duration (mins)</b><br>Maximum duration of Hold Alarm.  | 2 (0 to 999)     |

| No. | F or P | Description  | Setting (Limits)  |
|-----|--------|--|-------------------|
| 14  | P      | <b>Internal Overtemperature Alarm Setting (°C)</b><br>Not used if 5.1Kohm Resistor fitted.   | 80 (+50 to + 120) |
| 15  | P      | <b>Chill/Freeze Select (1/0)</b><br>Freeze (1) or Chill (0). Configures operation as a Chiller or Freeze.  | 0 (0 to 1)        |
| 16  | F      | <b>Maximum Chill Cooling Set Point (°C)</b><br>Maximum allowable Chill temperature Set Point. Active when Chiller Operation is selected (parameter 15=0).  | 10                |
| 17  | F      | <b>Minimum Chill Cooling Set Point (°C)</b><br>Minimum allowable Chill Set Temp. Point. Active when Blast Chiller Operation is selected (parameter 15=0).  | -15               |
| 18  | F      | <b>Maximum Freeze Cooling Set Point (°C)</b><br>Maximum allowable Freeze Temperature Set Point. Active when Freezer Operation is selected (parameter 15=1).  | 10                |
| 19  | F      | <b>Minimum Freeze Cooling Set Point (°C)</b><br>Minimum allowable Freeze Temperature Set Point. Active when Freezer Operation is selected (parameter 15=1).  | -35               |
| 20  | P      | <b>Surface Protection Temperature (°C)</b><br>Air Temperature Set Point during Cooling Phase when Surface Protection is active.  | -2 (+5 to -25)    |
| 21  | P      | <b>Surface Protection Time (%)</b><br>Under a Cooling Time Control Programme, the percentage of Cooling Time after which the Air Temperature Set Point rises to the value Surface Protection Temperature (20)                          | 70 (0 to 100)     |
| 22  | P      | <b>Surface Protection Food Temperature (°C)</b><br>Under a Food Temperature Control programme, the measured Food Temperature at which the Air Temperature Set Point rises to the value Surface Protection Temperature (20)             | 5 (-10 to +30)    |
| 23  | P      | <b>Surface Protection Limit (°C)</b><br>If the programmed Food Temperature (under a Food temperature Control programme), Air Temperature or Hold Temperature are above this value, the Surface Protection function cannot be selected. | -15 (5 to -15)    |

## 2.7 CONTROLLER FAULT FINDING

2.7.1 Before any checks are made to controller operation and the rear cover of the controller is removed, power **MUST BE** disconnected from the cabinet/counter.

2.7.2 Compressor and/or Evaporator fan(s) not working.

- Check operation of door switch(es). Door switches are of reed switch type which should be closed-circuit when door is closed (with switch adjacent to the magnet) and open circuit when door is open (with switch away from the magnet). Check switch operation by connecting a circuit tester across the switch outputs, when switch is disconnected from the controller board.

2.7.3 **Probe Fault** – PF1, PF2, PF3 or PF4.

- A probe fault occurs when the controller is unable to read the temperature probe. First, check the integrity of the probe connections to the controller board.
- Check the resistance of the temperature probe with the probe disconnected from the controller board, using an ohm meter. The temperature probes used are of the thermistor type, which change in resistance when subjected to a change in temperature. As temperature is seen to rise, the resistance of the probe should fall.

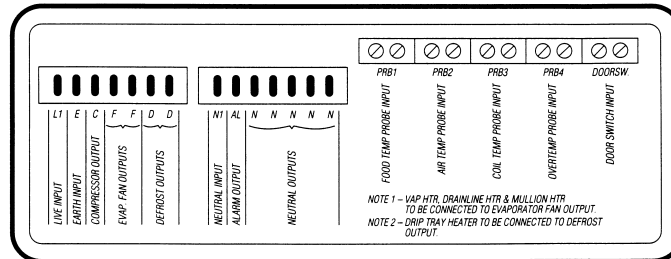

**No display or readout**

1. Check power supply for correct voltage.
2. Check connections onto L1, N1 & E.

**Displays P.F.1 (Food Probe)**

1. Check that Food Probe is connected correctly onto PRB1.
2. Check for damage to Food Probe.
3. Check resistance of Food Probe.
4. Change Food Probe if probe is open circuit or damaged.

**Displays P.F.2 (Air Probe)**

1. Check Air Probe connections onto PRB2.
2. Check position of Air Probe.
3. Check resistance of Probe.
4. Change Probe if resistance is incorrect or Probe open circuit.

**Displays P.F.3 (Evaporator Probe)**

1. Check Evaporator Probe connections on PRB3.
2. Check resistance of Probe.
3. Check position of Probe.
4. Change Probe if resistance is incorrect or Probe open circuit.

**Displays P.F.4 (Safety Cutout)**

1. Check that Probe is in the correct position.
2. Check resistance of Probe.
3. Change Probe if resistance is incorrect or Probe open circuit.
4. Check operation of cabinet after resetting.
5. Check temperature cutout on Defrost Mode.

**Evap. Fans not working**

1. If fans not working and LEDs illuminated on front panel, check connections on rear of controller marked 'F'.
2. Check connections for door switch.
3. Check to see if door switch is operating. Switch contacts should be closed when door is closed.

**Compressor not working**

1. If LED is illuminated on front panel, check output on rear of controller marked 'C'.
2. Check power going to compressor wiring.
3. Check door switch is operating. Switch contacts should be closed when door is closed.

**Evaporator iced up**

1. Enquire as to when last manual defrost was initiated.
2. Check defrost cycle by initiating manual defrost via front fascia operation. (A manual defrost can be started by holding down the 'Defrost key' and then pressing the 'Stop/Start' button at the same time).
3. Check output on rear of controller marked 'D'.
4. Check that 'Hot Gas Solenoid' valve is operating.
5. Check termination time and temperature settings on controller parameters.

2.7.4 **Resistance Values.**

For Probes 1, 2 and 3 (Food, Air and Evaporator) Probe fault occurs if a resistance corresponding to above +60°C (approximate values) is detected. See following temperature resistance values:

|       |           |       |           |       |             |
|-------|-----------|-------|-----------|-------|-------------|
| +60°C | 656 ohms  | +10°C | 3448ohms  | -20°C | 12100ohms   |
| +30°C | 1679 ohms | 0°C   | 5107 ohms | -30°C | 19455 ohms  |
| +20°C | 2381 ohms | -10°C | 7754 ohms | -60°C | 100181 ohms |

# 2.8 WIRING DIAGRAM

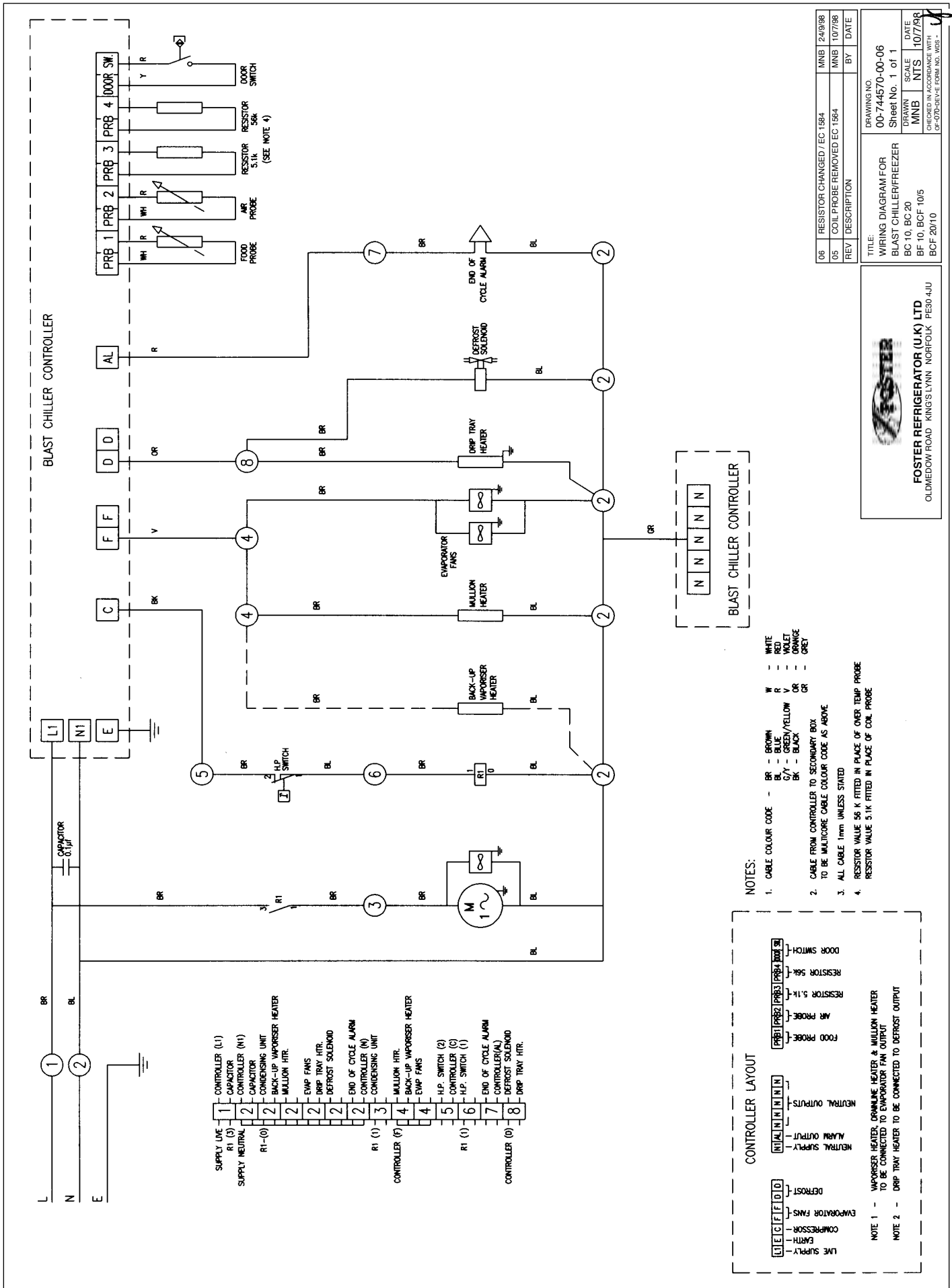

|     |                            |     |         |
|-----|----------------------------|-----|---------|
| 06  | RESISTOR CHANGED / EC 1584 | MNB | 24/9/98 |
| 05  | COIL PROBE REMOVED EC 1584 | MNB | 10/7/98 |
| REV | DESCRIPTION                | BY  | DATE    |

DRAWING NO. 00-744570-00-06  
 Sheet No. 1 of 1  
 DRAWN MNB SCALE NTS  
 DATE 10/7/98  
 CHECKED IN ACCORDANCE WITH CP-07D-BE-V-E FORM NO. 003 -

**FOSTER REFRIGERATOR (U.K) LTD**  
 OLDMEADOW ROAD KING'S LYNN NORFOLK PE30 4JU

# 2.8 WIRING DIAGRAM

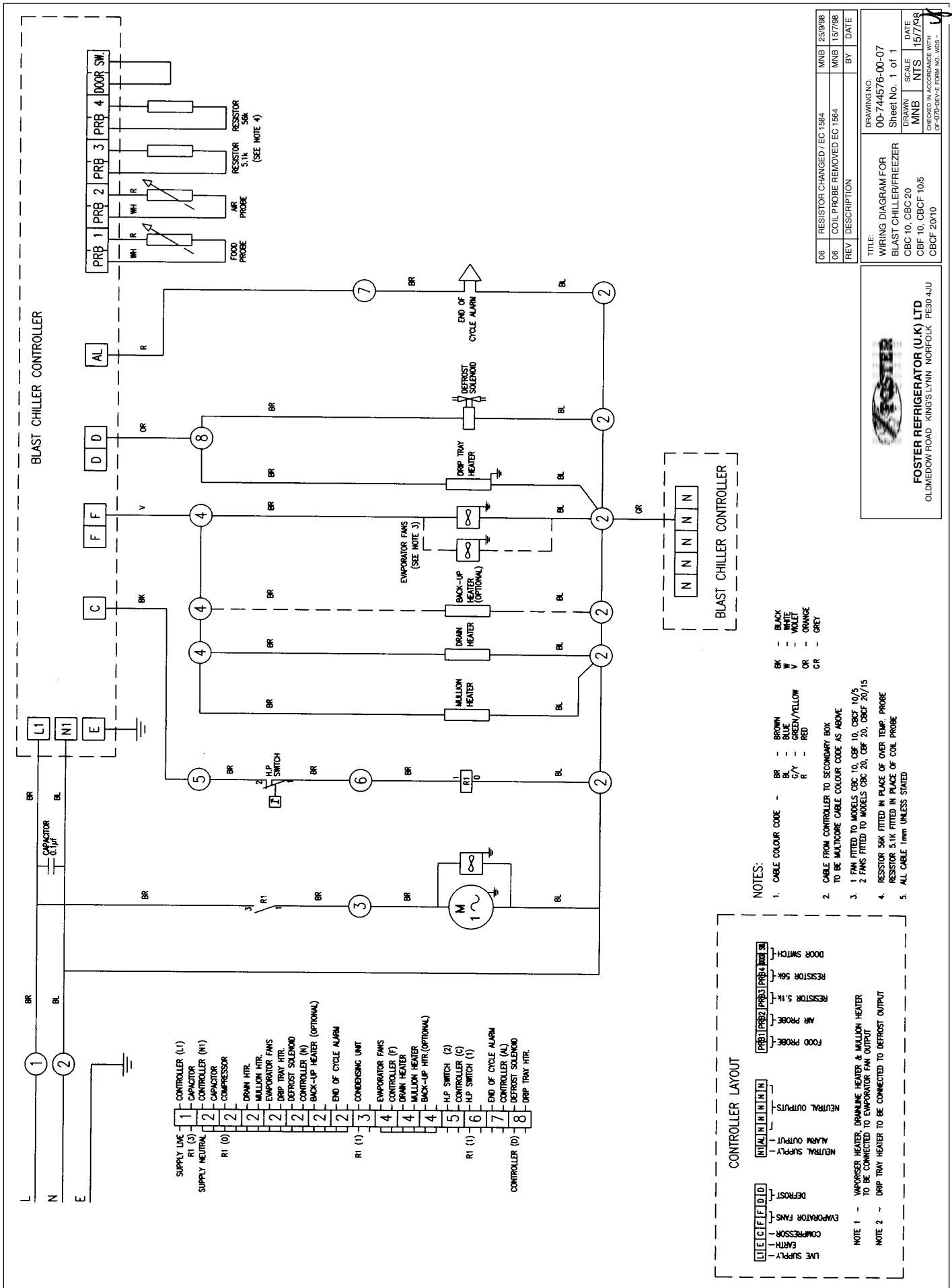

# 2.8 WIRING DIAGRAM

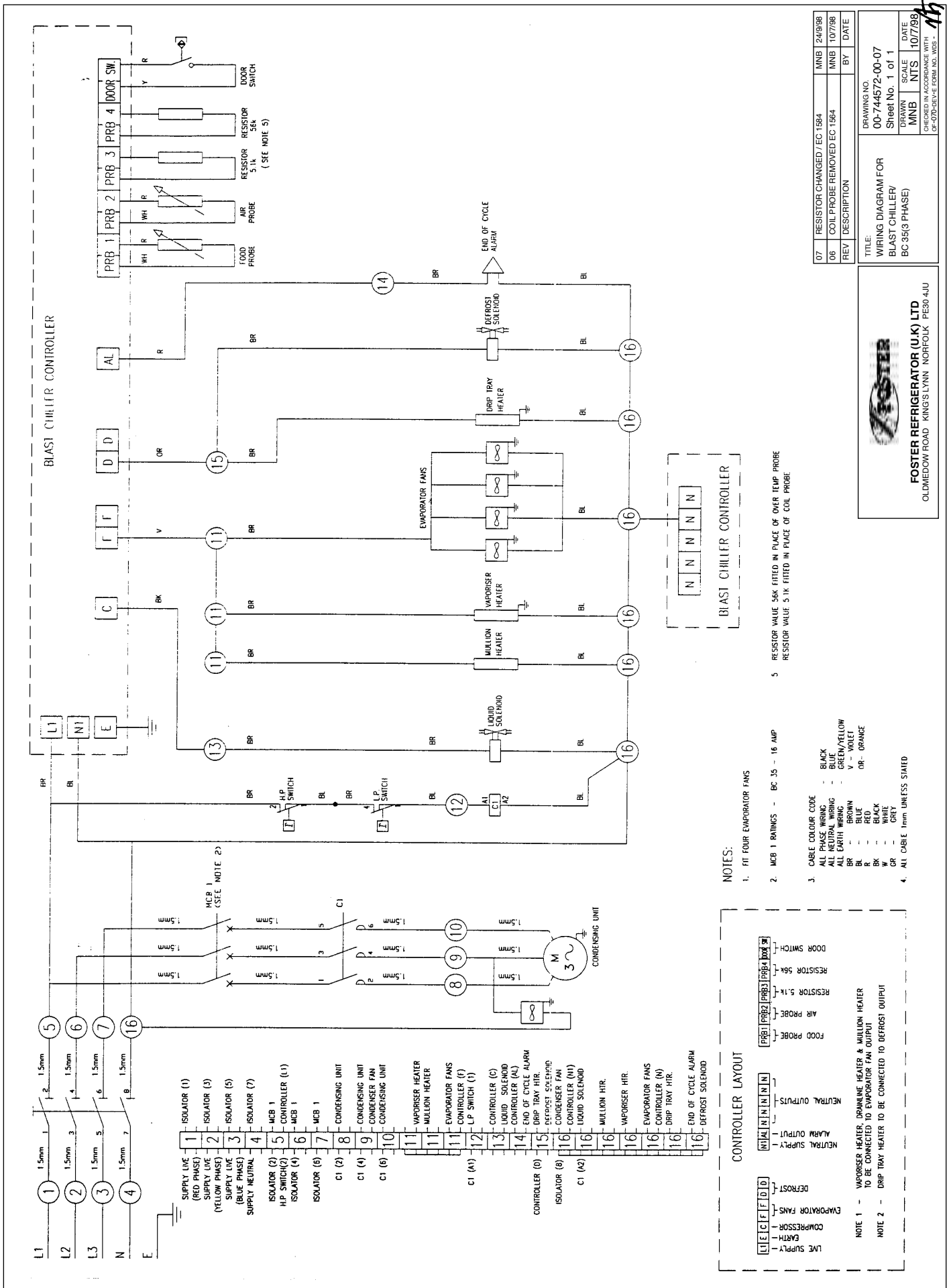

# **SECTION 3**

## **Modular BLAST CHILLERS & FREEZERS**



# 3.1 MODULAR BLAST CHILLERS & FREEZERS

## 1. OPERATING INSTRUCTIONS FOR THE Mk4 MICROPROCESSOR

As of Feb 2002.

### 1.1 INTRODUCTION

The MK4 cabinet and counter Blast Chiller Controller is a drop in replacement for the Mk3 Blast Chiller Controller. It is a microprocessor based temperature controller which may be fully programmed to perform process operations for various Chilling/Freezing applications.

The Controller performs many functions including Automatic Defrost Initiation & Full Alarm Warning. The display Fascia panel and microprocessor control board forms a single integral unit, from here to referred to as the Controller.

### 1.2 GENERAL SYSTEM OPERATION

The Controller applies proportional control of the refrigeration system components in order to maintain an integral air temperature necessary to cause rapid Chilling and Freezing.

Upon completion of the Chill or Freeze Phase; determined through product temperature measurement or a programmed time period, the internal air temperature will rise and be maintained to "Hold" the product in a chilled or frozen state.

### 1.3 CONTROLLER FRONT PANEL

The controller display is made up of the following components.



#### Sleep/Standby Button

Switches the Controller from the sleep mode; where seven bars are illuminated in the Display Windows ( - - - - - - - - ), to standby mode where the unit runs.



#### Start/Stop Button

Used to start and stop the Blast Chilling/Freezing Cycle.



#### Alarm Mute Button

Silences the End of Cycle alarm at the end of the Chilling/Freezing Cycle.



#### Print Button

A dual function button. If pressed and released the contents of the print log will be output to the printer. If pressed and held for a period of three seconds the print log is cleared – accompanied by an audible confirm (chirp).



#### Programme Button

A dual function button. If pressed and released the programme will change (from A to B, B to C through to J and back to A). If pressed and held for a period of three seconds the Controller enters the Setting Mode for a selected programme.



#### Increment Button

A dual function button. Primarily used when in the User and Service programming modes to change values. Can also be used when the unit is running to show Food/Air temperature: Whilst the button is pressed in a Time Cycle or Hold Mode the temperature display will show Food Probe temperature. Whilst button is pressed in a Food Probe Cycle the temperature display show Air Temperature.



#### Manual Defrost Button

Used to manually start Defrost (when the unit is in Standby or Hold mode).

### 1.4 INDICATING DISPLAYS AND LED'S



#### Time Display.

4 green 5 x 8 dot matrix LED segments show time left to run in Timed mode, 0000 in Food Temperature mode and shows Time Elapsed in Hold mode (time since end of cycle).



#### Temperature Display.

3 green 5 x 8 dot matrix LED segments show Air Temperature during Timed and Hold modes via Air Probe. Shows Product Temperature in Food Probe Mode via Food Probe. (By use of Increment Button the display will show the temperature of the Probe not controlling the cycle).



#### Food Probe Temperature LED.

Illuminates green during Product Cooling cycle, used in conjunction with Temperature Display.



#### Air Temperature LED.

Illuminates green during Timed Cycle and Hold Cycle – used in conjunction with Time Display and Temperature Display.



#### Hold Function LED.

Illuminated green to show when unit is in Hold Mode.



#### 'Hard Chill' Programme LED.

Illuminates green in conjunction with Programme LED's (programme A to J inclusive) to show that the selected programme is set as a 'Hard Chill Program'.



#### 'Soft Chill' Programme LED.

Illuminates green in conjunction with Programme LED's (programme A to J inclusive) to show that the selected programme is set as a 'Soft Chill Program'.



#### Programme Display

1 green 5 x 8 dot matrix LED segment shows the selected Programme (A to J inc). Also shows the Food Probe number (1, 2 or 3) when the three probe software is selected, and the Increment Button is pressed during a Cooling cycle or Hold mode.



#### Start/Running LED.

Illuminated green when the unit is in Timed/Product or Hold Modes. In conjunction with the Start/Stop Button.



#### End of Cycle LED.

Illuminated red when the End of Cycle Alarm has sounded and the Mute Button has been depressed. It is extinguished when the unit is stopped by pressing the Start/Stop Button.



#### Defrost Indication LED.

Illuminated red to Defrost in Operation – automatic or manual.



#### Condensing Unit Run LED.

Illuminated green when Condensing Unit output is high.



#### Evaporator Fan Run LED.

Illuminated green when Evaporator Fan output is high.



## **PROCEDURE FOR MODIFYING MODULAR BLAST CHILLER FROM ELM MK3/3A (ELM) CONTROLLER TO SUIT MK4 (ELM) CONTROLLER**

---

The MK4 controller is interchangeable with the Mk3/3A controller but care will need to be taken when connecting as the terminals on the Mk 4 controller are arranged differently but marked in the same way, with the exception of the Capacity control which is marked as 'P' Whereas previously it was marked as 'Cap'

The probes are arranged differently, with the exception of the over temp probe which is not required with the Mk4 control system.

For wiring detail consult Sheet 4 of Wiring Diagram 00-838137-00-07 and follow the instructions below :

- 1) Connect the Food probe to terminals 37 & 38 on the Control panel terminal rail. Connect controller/terminal rail interconnecting loom terminals Red and White cores to terminals 37 & 38 and Probe 1 on the controller.
- 2) Connect the Air probe to terminals 39 & 40 on the Control panel terminal rail. Connect controller/terminal rail interconnecting loom terminals Yellow and Blue cores to terminals 39 & 40 and probe 2 on the controller.
- 3) Connect the Coil probe to terminals 41 & 42 on the control panel terminal rail. Connect controller /terminal rail interconnecting loom terminals Black & Grey cores to terminals 41 & 42 and probe 3 on the controller.

# 1.5 Mk4 MODULAR BLAST CHILLER CONTROLLER OUTLINE OPERATING GUIDE

(Foster Part Number: 00-554482)

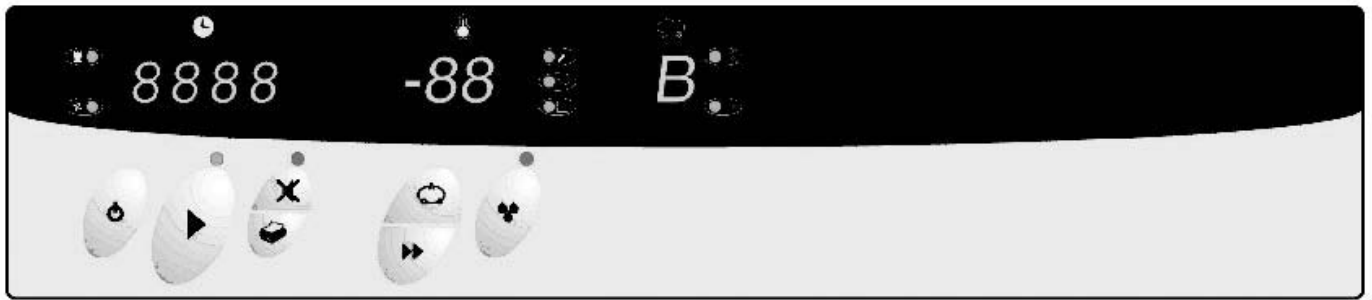

## 1.5.1 Controller Operation - Basic Functions

- Sleep / Standby Mode
- Program Chill / Freeze Program Start/Stop (Green LED illuminates during Program and Hold Modes)
- End of Cycle Alarm Mute Button Red LED illuminates once audible End of Cycle alarm has been muted)
- Print Data (Press once to print data / Press and Hold for 3 seconds to clear memory).

## 1.5.2 Controller Operation - Enhanced Functions

- Change Program (Program changes from A ⇒ B, B ⇒ C etc. until J ⇒ A. (Selected Program is Displayed)
- Change Program Parameters (Press and Hold for 3 seconds)
  - ◆ Minutes display flashes – adjust minutes value - save parameter value.
  - ◆ Hours display flashes – adjust hours value - save parameter value.
  - ◆ Probe Temp. flashes\* – adjust Food Temp. value - save parameter value.
  - ◆ Air Temp. flashes – adjust Air Temp. value - save parameter value.
  - ◆ Hold Temp. flashes – adjust Hold Temp. value - save parameter value.
  - ◆ Select Hard/Soft Chill – toggle Chill mode - save parameter value.
  - ◆ Set Print Sample Rate – increment sample rate - save parameter value and exit setting mode.
- Initiate Manual Defrost in Standby/Hold Mode (Red LED illuminates during defrost).

\*Only when Hours/Minutes parameter values set to 00:00

## 1.5.3 Displays and Indications

|  |                |  |              |  |               |  |                 |  |               |  |                   |  |                 |  |                  |  |                  |
|--|----------------|--|--------------|--|---------------|--|-----------------|--|---------------|--|-------------------|--|-----------------|--|------------------|--|------------------|
|  | Compressor LED |  | Time Display |  | Temp. Display |  | Probe Temp. LED |  | Air Temp. LED |  | Hold Function LED |  | Program Display |  | 'Hard' Chill LED |  | 'Soft' Chill LED |
|--|----------------|--|--------------|--|---------------|--|-----------------|--|---------------|--|-------------------|--|-----------------|--|------------------|--|------------------|

## 1.6 OPERATION

- 1.6.1 In this section the behaviour of the Controller is described in the form of a list of events with regard to the system refrigeration components.  
Where outputs are stated to be in a 'high' or 'low' state, a low state indicates the board relay output contacts to be open circuit and a high state indicates the relay to be closed and hence 'live'.
- 1.6.2 **Power Connected to Unit.**  
The Controller is in a sleep mode, seven bars are displayed on the fascia panel, all outputs are in a low state ( - - - - - ).
- 1.6.3 **Sleep/Standby Button Depressed.**  
The Controller switches on, fascia panel indicates programme, time and internal air temperature. Any one of the stored programs may be selected by pressing the programme button. Programme settings may be altered by following the User Setting Procedure.
- 1.6.4 **Start/Stop Button Depressed.**  
The selected Controller programme is initiated.
- 1.6.5 **Cooling Phase.**  
If the selected programme is a Food Temperature Control programme, the following sequence of events will occur:  
The fascia panel displays Cooling Time (set to zero) and product Temperature (measured by the Food Probe).  
The refrigeration cycle begins and the Evaporator Fan output remains high throughout the cycle except if the door is opened.  
The Cooling Time displayed in the fascia panel will increment from zero.  
If internal air temperature is higher than the pre-set Air Temperature the Condensing Unit output goes high.  
When the internal air temperature pulls down to the pre-set Air Temperature the Condensing Unit output goes low.  
The Cooling Phase continues until the pre-set Product Temperature is reached.  
The end of cycle alarm sounds and the Unit enters the Hold phase (Hold LED illuminated).  
The displayed Cooling Time stops incrementing and holds the displayed value.  
The Temperature Display changes to indicate Internal Air Temperature.  
If the selected programme is a Cooling Time Control programme, the following sequence of events will occur:  
The fascia panel displays Cooling Time and Air Temperature.  
The refrigeration cycle begins and the Evaporator Fan output remains high throughout the cycle except if the door is opened.  
The Cooling Time displayed on the fascia panel will decrement from the programmed value.  
If internal air temperature is higher than the pre-set Air Temperature, the Condensing Unit output goes high.  
When the internal air temperature pulls down to the pre-set Air Temperature, the Condensing Unit output goes low.  
If the internal air temperature then rises above the pre-set Air Temperature plus the Differential, the Condensing Unit goes High.  
The Cooling time continues until the displayed time increments to zero.  
The end of cycle alarm sounds and the Unit enters the Hold phase (Hold LED illuminated).
- 1.6.6 **Hold Phase.**  
With the evaporator fan output still high, the condensing unit output falls low until the internal air temperature rises to the pre-set Hold Temperature plus the Hold Temperature Differential.  
The Condensing Unit output goes high until the internal air temperature pulls down to the pre-set Hold Temperature.  
The Hold Phase continues until the programme is stopped by operation of the Start/stop button.
- 1.6.7 **End of Cycle Alarm.**  
The Controller alarm output will go high on entry to the Hold Phase to indicate completion of the Cooling Phase.  
The Hold Alarm will stay high for the period Hold alarm Duration.  
Alternatively, the Hold Alarm may be muted by operation of the fascia Mute button.  
However the Hold LED above the Mute button will illuminate.
- 1.6.8 **Defrost Automatic or Manually Initiated.**  
The time period to the first defrost is calculated from the start of the Cooling Programme.  
If the Defrost interval is every 4 hours but the Cooling Cycle is 6 hours the Defrost will be postponed until the Unit enters Hold Mode.  
Defrosts will occur automatically in the Hold Mode. The evaporator fan output falls low.  
Depending on Defrost Type, either a Hot Gas (Type = 1) or Electric Heater (Type = 0) Defrost will be initiated and the Time Display will continue to display Time Elapsed. The temperature display will show the temperature measured by the Food Probe. The RED LED will illuminate.  
Alternatively, a Defrost can be initiated in the 'Standby' or 'Hold' modes.  
To initiate a Manual Defrost press the Defrost button once and defrost will commence.  
Defrost will be the same as in automatic mode.

## 1.7 ERROR ANNUNCIATION

Should temperature probe failure occur the controller will indicate the fault by flashing on the fascia panel: **PF1, PF2, PF3, PF4 or PF5** in the temperature display window.

It is important to note that on Probes 1 and 2 Probe Fault occurs if a resistance corresponding to above +60°C or below -60°C. See page 33 for resistance values against temperature.

**PF1 — Indicates Food Probe failure.**

If a food probe fault occurs during a Food Temperature Control Programme the Condensing Unit output goes low.  
If a Food Probe fault occurs during a Cooling Time Programme the Controller will continue to operate normally.

**PF2 — Indicates Air Probe Failure.**

If an Air Probe fault occurs during either a Food Temperature or Cooling Time Control Programme the Condensing Unit output goes low.

**PF3 — Indicates Evaporator Coil Failure.**

A probe is not fitted, however in its place a 5.1 Kohm resistor is fitted. If this fails it will not effect the cooling cycle as the defrost will terminate using the time setting.

**PF4 & PF5 — Indicates Food Probe 2 & 3 Failures respectively.**

Displayed only in standby mode, this fault will only register if the probe software is activated. There is no effect on unit operation or programming.

## 1.8 HARD OR SOFT CHILL

Hard/Soft Chilling is used to minimise surface damage to delicate products.

The Soft Chill function raises the Air Temperature during the latter part of the Cooling Phase. The Air Temperature during the Cooling Phase, while Soft Chill is selected, rises to the value of the Soft Chill Set Parameter temperature.

Under a Cooling Time Control Programme the Soft Chill level becomes active after the percentage value of the Soft Chill Set Time relative to the pre-set Cooling Time has lapsed.

Under a Food Temperature Control Programme, the Soft Chill becomes active when the Soft Chill Food Temperature, measured by the Food Probe is reached.

Soft Chilling can only be selected if the Programme Settings — Food Temperature, Cooling Air Temperature and Hold Air Temperature are set above the value of the Surface Protection Limit.

## 1.9 USER PROGRAMME SETTINGS

The following is a list of the parameters that may be adjusted by the user in the programmes A to J.

### 1.9.1 Cooling Time. Control Programme (Hrs : Mins).

Duration of Cooling Phase for a Cooling Time Control Programme.

If set to zero, the Controller automatically assumes a Food Temperature Control Programme.

### 1.9.2 Food Temperature. Control Programme (°C).

Desired Food Temperature at completion of the Cooling Phase.

Required when a Food Temperature Control Programme is selected.

Measured by the Food Probe inserted into the product to be cooled.

### 1.9.3 Cooling Air Temperature (°C).

Internal air temperature during the Cooling Phase.

### 1.9.4 Hold Air Temperature (°C).

Internal air temperature during the Hold Phase.

### 1.9.5 Cooling Type ('Hard' or 'Soft' Chill).

Selects cooling type function, which in Soft Chill raises the Air Temperature during the latter part of the Chill Phase.

Soft Chill can only be selected if the Programme Settings — Food, Chill Air & Hold Air Temperature are above the value of the Soft Chill Limit.

### 1.9.6 Printer Sample Rate.

Selects the interval between Air or Food temperature samples being recorded during the Cooling Cycle and Hold Mode.

## 1.10 PROGRAMME SETTING AND CONTROL PARAMETER ADJUSTMENT

The user can tailor the Programme Settings to suit the particular product to be cooled.

Settings can be saved in up to ten programmes, stored by the controller (A to J inclusive).

The Controller is pre-set with three typical programmes. Programme D to J are unprogrammed.

### Chill Programme (P15 = 0)

|                        | Programme A | Programme B | Programme C |
|------------------------|-------------|-------------|-------------|
| Time                   | 1 Hr 30 min | 0.00 Hrs    | 1 Hr 30 min |
| Food Temperature Probe | NA          | +3°C        | NA          |
| Air Temperature Probe  | -10°C       | -10°C       | -10°C       |
| Hold Temperature       | +3°C        | +3°C        | +3°C        |
| Chill Mode             | HARD        | HARD        | SOFT        |
| Print Sample Rate      | 3           | 3           | 3           |

### Chill/Freeze and Freeze Programme (P15 = 1)

|                        | Programme A | Programme B | Programme C |
|------------------------|-------------|-------------|-------------|
| Time                   | 3 Hr        | 0.00 Hrs    | 1 Hr 30 min |
| Food Temperature Probe | NA          | -21°C       | NA          |
| Air Temperature Probe  | -30°C       | -30°C       | -10°C       |
| Hold Temperature       | -21°C       | -21°C       | +3°C        |
| Chill Mode             | HARD        | HARD        | SOFT        |
| Print Sample Rate      | 3           | 3           | 3           |

Control Parameters alter the characteristics of the chilling or freezing process. They should not be adjusted without a good understanding of the operation of the Controller.

If no button is pressed for a period of two minutes the controller will revert to the standby mode without saving any of the modified settings.

## 1.11 SERVICE PARAMETERS

- 1.11.1
- It is strongly advised that before adjusting any Service Parameter a thorough understanding of the Blast Chiller operating principles are obtained.
  - The Service Parameters are accessed in the following way.
  - Put the control panel into the 'Sleep' Mode. Press the Programme button and hold while pressing the Increment button. The Controller is now in the Service Parameter settings, release both buttons.
  - To save a value, press the Programme button.
  - To change a value press the Increment button till you get the desired value.
  - To exit and save the new Control Parameter values, the 'Start/Stop' button must be pressed. The controller reverts to the 'on' condition. If any other buttons are pressed the changed values will not be held.
  - If not buttons are pressed for two minutes whilst in the Service Parameter Setting Mode the controller will revert to the 'Sleep State' without saving any of the changes.

1.11.2 Control Parameters – Fixed or Programmable (F or P)

| No. | F or P | Description  | Settings (Limits) |
|-----|--------|--|-------------------|
| 1   | P      | <b>Cooling Temperature Differential (°C)</b><br>Cooling Set Point + Cooling Temperature Differential = High point of the cooling operation range.  | 3 (1 to 10)       |
| 2   | P      | <b>Hold Temperature Differential (°C)</b><br>Hold Set Point + Hold Temperature Differential + hold point of Hold operating range.  | 3 (1 to 10)       |
| 3   | P      | <b>Compressor Rest Time (Mins)</b><br>Minimum Time between successive compressor operations  | 0 (0 to 10)       |
| 4   | P      | <b>Defrost Termination Temperature (°C) – (NOT USED)</b><br>To be used with suitable Evaporator Temperature Probe  | 20 (0 to 50)      |
| 5   | P      | <b>Defrost Termination Time (Mins)</b><br>Maximum defrost time duration  | 6 (0 to 60)       |
| 6   | P      | <b>Number of Defrosts Per Day</b><br>Determines duration between automatic defrosts  | 6 (0 to 24)       |
| 7   | P      | <b>Defrost Type (1/0)</b><br>Hot Gas (1) or Electric (0), determines whether both the defrost and condensing unit outputs or the defrost output alone goes high when a defrost is initiated.                     | 1 (0 to 1)        |
| 8   | P      | <b>Drain Down Time (Mins)</b><br>Time period after defrost for which the Defrost and Condensing Unit outputs remain low.   | 5 (0 to 24)       |
| 9   | P      | <b>Fan Delay Time (Mins)</b><br>Time period after Drain Down Time for which Evaporator Fan output remains low.   | 1 (0 to 20)       |
| 10  | P      | <b>Fan Delay Temperature (°C) – (NOT USED)</b><br>To be used with suitable Evaporator Temperature Probe.   | 0 (-20 to 20)     |
| 11  | P      | <b>Cabinet Identification Number</b><br>Used to set the number printed out at the head of the Print Log to identify the Controller/Cabinet.  | 1 (0 to 255)      |
| 12  | P      | <b>Print Out Language</b><br>Determines the Language Printed when Downloading the Print Log.<br>(0= English, 1=Danish, 2=Dutch, 3=French, 4=German, 5=Italian, 6=Spanish, 7=Swedish).                            | 0 (0 to 7)        |
| 13  | P      | <b>Hold Alarm Duration (Mins)</b><br>Maximum Duration of Hold Alarm.   | 2 (0 to 99)       |
| 14  | P      | <b>Display Offset</b><br>Allows the display temperature to be adjusted up or down to allow for system tolerances.  | 0 (-15 to 15)     |
| 15  | P      | <b>Chill/Freeze Select (1/0)</b><br>Chill (0) or Freeze (1) Configures operation as a Chiller or Freezer   | 0 (0 to 1)        |
| 16  | F      | <b>Maximum Chill Cooling Set Point (°C)</b><br>Maximum allowable Chill Temperature Set Point.<br>Active when Chiller Operation is selected. (parameter 15=0)   | 10                |
| 17  | F      | <b>Minimum Chill Cooling Set Point (°C)</b><br>Minimum allowable Chill Temperature Set Point.<br>Active when Chiller Operation is selected. (parameter 15=0)   | -15               |
| 18  | F      | <b>Maximum Freeze Cooling Set Point (°C)</b><br>Maximum allowable Freeze Temperature Set Point.<br>Active when Freeze Operation is selected (parameter 15=1)   | 10                |
| 19  | F      | <b>Minimum Freeze Cooling Set Point (°C)</b><br>Minimum allowable Freeze Temperature Set Point.<br>Active when Freeze Operation is selected. (parameter 15=1)  | -35               |
| 20  | P      | <b>'Soft' Chill Temperature (°C)</b><br>'Soft' Chill Air Temperature Set point during Cooling Phase when 'Soft' Chill is active.   | -2 (-25 to 5)     |
| 21  | P      | <b>'Soft' Chill Time (%)</b><br>Under a Cooling Time Control Program the percentage of Cooling Time after which the Air Temperature Set Point rises to the value 'Soft' Chill Temperature                        | 70 (0 to 100)     |
| 22  | P      | <b>'Soft' Chill Food Temperature (°C)</b><br>Under a Food Temperature Control Program the measured Food Temperature at which the Air Temperature Set Point rises to the value 'Soft' Chill Temperature.          | 5 (-10 to +30)    |
| 23  | P      | <b>'Soft' Chill Limit (°C)</b><br>If the programmed Food Temperature (under a Food Temperature Control Programme) is above the Air Temperature or Hold Temperature the 'Soft' Chill function cannot be selected. | -15 (+5 to -15)   |
| 24  | P      | <b>Graph Print Out Low Point</b>   | -10 (-30 to +30)  |
| 25  | P      | <b>Year</b>  | 00 (00 to 99)     |
| 26  | P      | <b>Months</b>  | 01 (01 to 12)     |
| 27  | P      | <b>Date</b>  | 01 (01 to 31)     |
| 28  | P      | <b>Time – Hours</b>  | 00 (00 to 23)     |
| 29  | P      | <b>Time – Minutes</b>  | 00 (00 to 59)     |
| 30  | P      | <b>Three Probe Software (0=Not Active, 1 = Active)</b><br>Three Probe software selects whether the optional probe numbers 2 and 3 are active, and allows temperature to be selected.                             | 0 (0 to 1)        |
| 31  | P      | <b>Capacity Control Limit (°C)</b>   | 0 (-15 to 5)      |

1.11.3 **Service Parameters – Additional Information.**

- **Display Offset (P14).** Allows the display temperature (and hence operating temperature) to be adjusted up or down to allow for systems tolerances. This provides a higher level of temperature accuracy.
- **Graph Print Out Low Point.** The service graph print out has a range of 60°C. This parameter sets a low point of the graph (example of P24 is set to -10°C the graph will show the temperature/time between +50°C to -10°C). The graph function is intended to assist the Service Operation Settings and testing.
- **Date/Time Settings (P25/P26/P27/P28/P29).** These values are used in the Real Time Clock (RTC), the times and dates are printed with temperature data from the print log. Under normal circumstances the controller will be pre-programmed with the correct Time and Date (GMT or BST). No account is taken for international time zones; therefore some adjustments may be necessary. The controller is fitted with a PCB battery, which will retain time date setting if the electrical supply is removed/isolated once set.
- **Three Probe Software.** Allows the three probe temperatures to be displayed. The two additional probes ( probes 2 and 3) are for information only and do not perform any control function. When P30 is set to 0, pressing the increment button will cause the temperature display to show either Air or Food probe temperatures. When P30 is set to 1, pressing the increment button will cause the temperature display to show Food Probe 1 temperature when in a timed chill or hold mode. When pressed during a Food probe cycle the programme display will show 2 along with the temperature received by that probe for 3 seconds, displayed in the temperature display. The programme display will then show 3, followed by temperature measured by Probe 3 in the temperature display for the same time period of 3 seconds. On completion the temperature will return to showing the probe 1 temperature.
- **Capacity Control.** The function controls the condensing unit or evaporator fans during periods when the required internal air temperature is above the value set for the Capacity Control in the Service Parameters (31).  
In basic terms if the capacity control value is set to 0°C, (default value) and in a Timed Chill mode the air temperature is set to 3°C, the capacity control output will be active, thereby reducing the refrigeration system capacity (depending on wiring).  
It would be more usual for the for the capacity control only to become active in the Hold mode when the hold temperature would be set for 3°C. The capacity control is active if the above conditions are met in the Timed chill or Hold modes (It is not used for freezer applications).

**1.12 CONTROLLER MODEL SELECTION**

1.12.1 The controller holds the Standard Operating Settings for 16 (0 to 15 inclusive) Blast Chiller and Blast Freezer models (both integral and remote). to select the appropriate models Bit Switches are used. The Bit Switches are a series of 4, two position switches (see below) situated on the back of the controller PCB and which can be accessed with the rear cover removed.

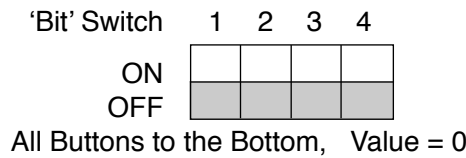

1.12.2 Using binary Notation – values between 0 and 15 can be obtained.

The Bit pattern settings to access these are as follows:

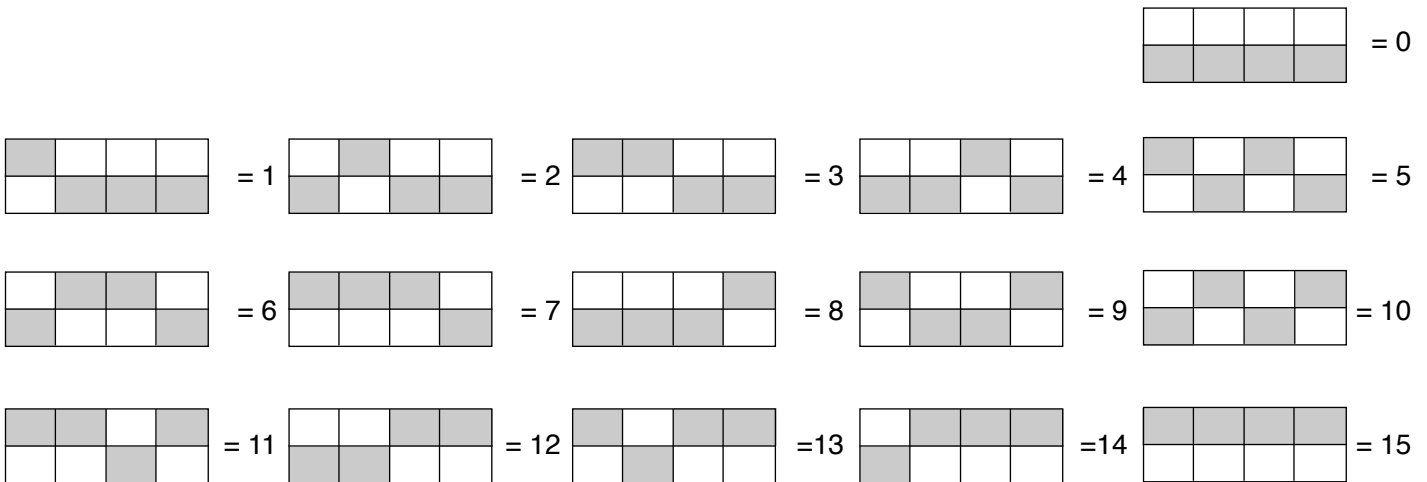

1.12.3 By setting the bit switches to the appropriate positions various Operating Parameters are selected.

- If setting 6-15 inclusive are selected the unit will not function as these are not currently pre-programmed.
- A full breakdown of the Pre-set Values is shown on the next page.
- Should any programme need to be changed the User Programme Setting Procedure on page 27 must be followed.
- Should any parameters require changing the Service Parameter Setting Procedure on pages 29 & 30 must be followed.

### 1.12.4 Controller Model Selection Table

| Denomination               |                                       | BC<br>(R) | BF<br>(R) | BC/F<br>(R) | FBC<br>(R) | FBF<br>(R) | FBC/<br>F(R) | Settings 6 to 15 are not used |  |  |  |  |  |  |  |  |  |  |  |  |  |
|----------------------------|---------------------------------------|-----------|-----------|-------------|------------|------------|--------------|-------------------------------|--|--|--|--|--|--|--|--|--|--|--|--|--|
| <b>BIT Switch Settings</b> |                                       | 0         | 1         | 2           | 3          | 4          | 5            |                               |  |  |  |  |  |  |  |  |  |  |  |  |  |
| P1                         | Cooling Temperature Differential (°C) | 3         | 3         | 3           | 3          | 3          | 3            |                               |  |  |  |  |  |  |  |  |  |  |  |  |  |
| P2                         | Hold Temperature Differential (°C)    | 3         | 3         | 3           | 3          | 3          | 3            |                               |  |  |  |  |  |  |  |  |  |  |  |  |  |
| P3                         | Compressor Rest Time (mins)           | 0         | 0         | 0           | 0          | 0          | 0            |                               |  |  |  |  |  |  |  |  |  |  |  |  |  |
| P4                         | Defrost Termination Temperature (°C)  | 20        | 20        | 20          | 20         | 20         | 20           |                               |  |  |  |  |  |  |  |  |  |  |  |  |  |
| P5                         | Defrost Termination Time (mins)       | 12        | 12        | 12          | 12         | 12         | 12           |                               |  |  |  |  |  |  |  |  |  |  |  |  |  |
| P6                         | Number of Defrosts (per day)          | 6         | 6         | 6           | 6          | 6          | 6            |                               |  |  |  |  |  |  |  |  |  |  |  |  |  |
| P7                         | Defrost Type (0=elec/ 1=hot gas)      | 0         | 0         | 0           | 0          | 0          | 0            |                               |  |  |  |  |  |  |  |  |  |  |  |  |  |
| P8                         | Drain Down Time (mins)                | 5         | 5         | 5           | 5          | 5          | 5            |                               |  |  |  |  |  |  |  |  |  |  |  |  |  |
| P9                         | Fan Delay Time (mins)                 | 1         | 1         | 1           | 1          | 1          | 1            |                               |  |  |  |  |  |  |  |  |  |  |  |  |  |
| P10                        | Fan Delay Temperature (°C)            | 0         | 0         | 0           | 0          | 0          | 0            |                               |  |  |  |  |  |  |  |  |  |  |  |  |  |
| P11                        | Cabinet ID Number                     | 1         | 1         | 1           | 1          | 1          | 1            |                               |  |  |  |  |  |  |  |  |  |  |  |  |  |
| P12                        | Print Out Language                    | 0         | 0         | 0           | 3          | 3          | 3            |                               |  |  |  |  |  |  |  |  |  |  |  |  |  |
| P13                        | Hold Alarm Duration (mins)            | 2         | 2         | 2           | 2          | 2          | 2            |                               |  |  |  |  |  |  |  |  |  |  |  |  |  |
| P14                        | Display Offset                        | 0         | 0         | 0           | 0          | 0          | 0            |                               |  |  |  |  |  |  |  |  |  |  |  |  |  |
| P15                        | Chill (0) / Freeze (1) Select         | 0         | 1         | 1           | 0          | 1          | 1            |                               |  |  |  |  |  |  |  |  |  |  |  |  |  |
| P16                        | Max. Chill Cooling Set Point (°C)     | 10        | 10        | 10          | 10         | 10         | 10           |                               |  |  |  |  |  |  |  |  |  |  |  |  |  |
| P17                        | Min. Chill Cooling Set Point (°C)     | -15       | -15       | -15         | -15        | -15        | -15          |                               |  |  |  |  |  |  |  |  |  |  |  |  |  |
| P18                        | Max. Freeze Cooling Set Point (°C)    | 10        | 10        | 10          | 10         | 10         | 10           |                               |  |  |  |  |  |  |  |  |  |  |  |  |  |
| P19                        | Min. Freeze Cooling Set Point (°C)    | -35       | -35       | -35         | -35        | -35        | -35          |                               |  |  |  |  |  |  |  |  |  |  |  |  |  |
| P20                        | Soft Chill Temperature (°C)           | -2        | -2        | -2          | -2         | -2         | -2           |                               |  |  |  |  |  |  |  |  |  |  |  |  |  |
| P21                        | Soft Chill Time (%)                   | 70        | 70        | 70          | 70         | 70         | 70           |                               |  |  |  |  |  |  |  |  |  |  |  |  |  |
| P22                        | Soft Chill Food Temperature (°C)      | 5         | 5         | 5           | 5          | 5          | 5            |                               |  |  |  |  |  |  |  |  |  |  |  |  |  |
| P23                        | Soft Chill Limit (°C)                 | -15       | -15       | -15         | -15        | -15        | -15          |                               |  |  |  |  |  |  |  |  |  |  |  |  |  |
| P24                        | Graph Print Out Low Point             | -10       | -10       | -10         | -10        | -10        | -10          |                               |  |  |  |  |  |  |  |  |  |  |  |  |  |
| P25                        | Year                                  | 00        | 00        | 00          | 00         | 00         | 00           |                               |  |  |  |  |  |  |  |  |  |  |  |  |  |
| P26                        | Month                                 | 01        | 01        | 01          | 01         | 01         | 01           |                               |  |  |  |  |  |  |  |  |  |  |  |  |  |
| P27                        | Date                                  | 01        | 01        | 01          | 01         | 01         | 01           |                               |  |  |  |  |  |  |  |  |  |  |  |  |  |
| P28                        | Hours                                 | 00        | 00        | 00          | 00         | 00         | 00           |                               |  |  |  |  |  |  |  |  |  |  |  |  |  |
| P29                        | Minutes                               | 00        | 00        | 00          | 00         | 00         | 00           |                               |  |  |  |  |  |  |  |  |  |  |  |  |  |
| P30                        | 3 Probe Software                      | 0         | 0         | 0           | 0          | 0          | 0            |                               |  |  |  |  |  |  |  |  |  |  |  |  |  |
| P31                        | Capacity Control                      | 0         | 0         | 0           | 0          | 0          | 0            |                               |  |  |  |  |  |  |  |  |  |  |  |  |  |

## 1.13 ELECTRICAL CONNECTIONS

### 1.13.1 Ratings

|                         |                 |                    |            |
|-------------------------|-----------------|--------------------|------------|
| Nominal Supply Voltage: | 230Va.c. +/-10% | Supply Frequency:  | 50 / 60 Hz |
| Supply Range:           | 198-254Va.c.    | Temperature Range: | 0 to +70°C |
| Humidity                | 80%             |                    |            |

### 1.13.2 Mains Services

|                              |   |
|------------------------------|---|
| Mains Supply:                | 1 Live (L1), 1 Neutral (N1), 1 Earth (E). |
| Compressor / Solenoid Valve: | 1 Switched Live (C).                      |
| Evaporator Fans:             | 2 Switched Live (F).                      |
| Defrost:                     | 2 Switched Live (D).                      |
| Alarm:                       | 1 Switched Live (A).                      |
| Common Neutral:              | 5 Neutral (N).                            |

### 1.13.3 Sensors

|                     |                           |
|---------------------|---------------------------|
| Printer Connection: | Plug In Connection.       |
| Food Probe:         | 2 Screw Terminals (PRB1). |
| Air Probe:          | 2 Screw Terminals (PRB2). |
| Resistor 5.1Kohm:   | 2 Screw Terminals (PRB3). |
| Door Switch:        | 2 Screw Terminals (DS).   |
| Food Probe:         | 2 Screw Terminals (PRB4). |
| Food Probe:         | 2 Screw Terminals (PRB5). |

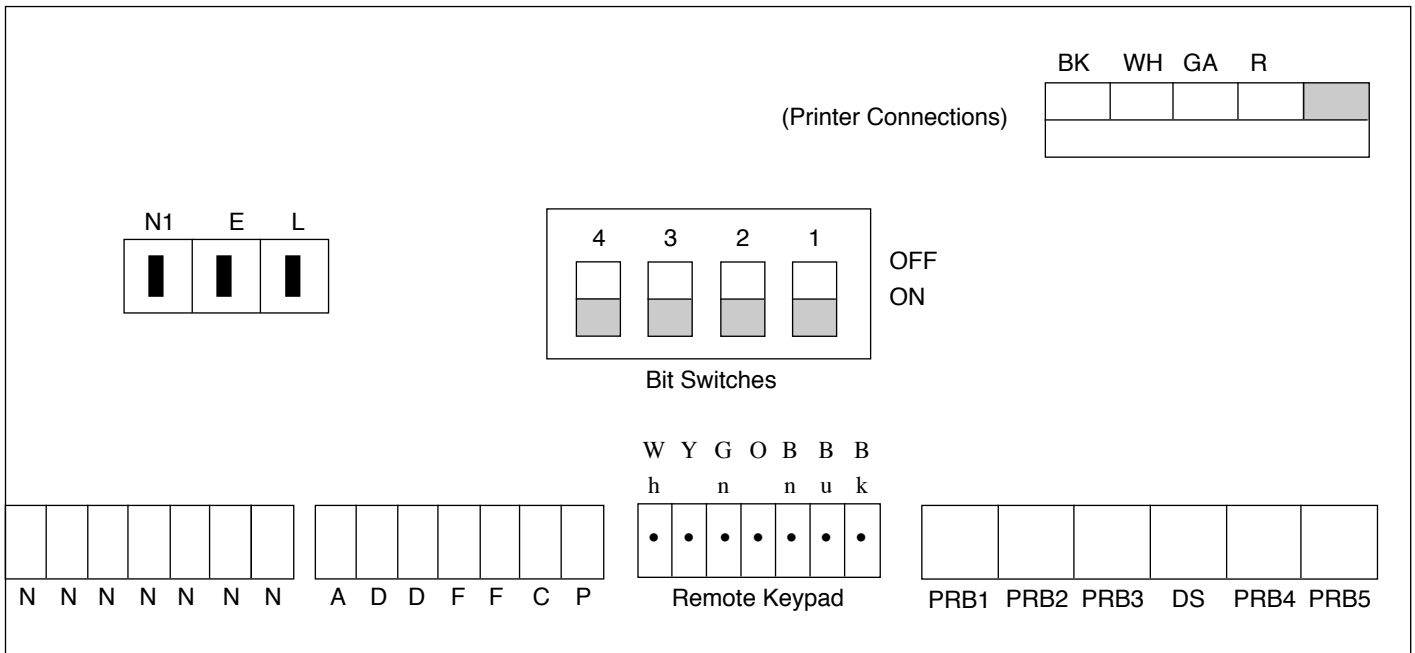

## 1.14 RESISTANCE VALUES:

The following table relates to resistance values against temperature.

|       |           |       |           |       |             |
|-------|-----------|-------|-----------|-------|-------------|
| +60°C | 656 ohms  | +10°C | 3448 ohms | -20°C | 12100 ohms  |
| +30°C | 1679 ohms | 0     | 5107 ohms | -30°C | 19455 ohms  |
| +20°C | 2381 ohms | -10°C | 7754 ohms | -60°C | 100181 ohms |



## 3.2 MODULAR BLAST CHILLERS & FREEZERS

### 2.0 USER OPERATION GUIDELINES

From Feb 1997 to Feb 2000

The Modular Blast Chiller/Freezer Temperature Controller maintains and displays a coldroom air temperature for a time period necessary to chill or freeze the stored product. The Controller also carries out automatic defrosting and performs various alarm functions.

#### 2.1 FASCIA INDICATORS AND KEYS

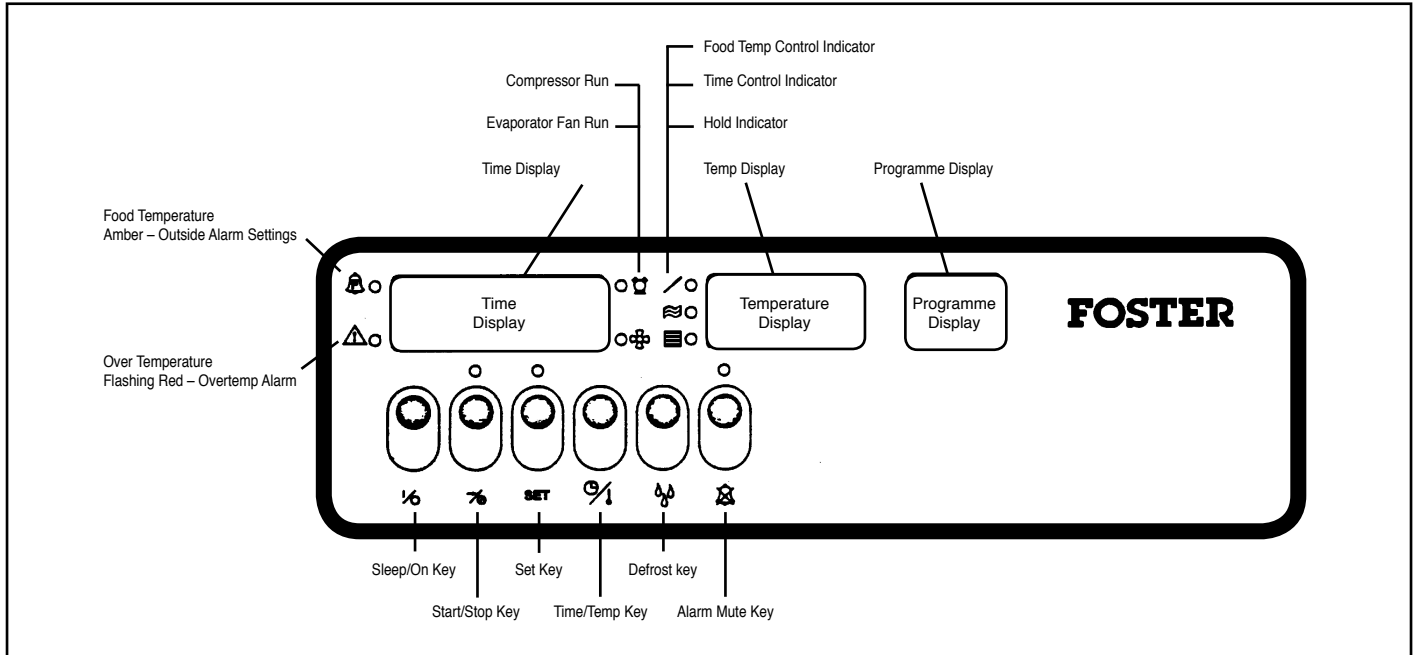

##### 2.1.1 Indicators

**Temp Display** - Normally indicates Food Probe Temperature during a Food Temperature Control Programme or Air Temperature during a Time Control Programme.

**Time Display** - Normally indicates Elapsed Cooling Time during a Food Temperature Control programme or Remaining Cooling Time during a Time Control Programme.

**Programme Display** - Normally indicates current selected programme.

**Food Temperature Indicator** - Illuminated amber if the temperature of the stored product falls outside preset alarm limits. Extinguished when the stored product temperature falls back within alarm limits. The Controller calculates the temperature of the stored product during the Hold Phase through monitoring internal air temperature.

**Overtemperature Indicator** - Flashes red in the event of the internal temperature exceeding the preset Overtemperature Alarm Setting. The Controller Alarm output will also go high.

**Compressor Run Indicator** - Illuminated green while the compressor will cycle on and off to maintain the desired internal air temperature. Compressor will stop if the door is left open for longer than one minute.

**Evaporator Fan Run Indicator** - Illuminated green while the evaporator fans are running. Evaporator fans will stop if the door is opened.

**Food Temperature Control Indicator** - Illuminated green if a Food Temperature Control Programme is selected.

**Time Control Indicator** - Illuminated green if a Time Control Programme is selected.

**Hold Indicator** - Illuminated green during the Hold Phase.

**Run Indicator** - Indicator above '⏸' key, illuminated green while a programme is initiated.

**Programme Indicator** - Indicator above the 'SET' key, illuminated green during Controller programming.

**Hold Alarm Indicator** - Indicator above the '🔇' key, illuminated green after Hold Alarm is muted.

##### 2.1.2 FASCIA KEYS

**Sleep/On Key** (⏸) - Switches the Controller between 'sleep' and 'on' states.

**Start/Stop Key** (⏹) - Initiates or terminates a selected cooling programme.

**Set Key (SET)** - Used to enter programming sequence and acknowledge programme settings.

**Time/Temp Key** (🌡) - Used to alter time and temperature values during the programming sequence. During a Time Control Programme, used to view temperature of Food Probe(s). During a Food Temperature control Programme, used to view Air Temperature (and temperature of additional Food Probes). During a Defrost, used to view Evaporator Temperature.

**Defrost Key** (🧊) - Hold down this key and press the '⏹' key to manually initiate a defrost.

**Alarm Mute Key** (🔇) - Used to mute the audible Hold Alarm permanently or the Food Temperature Alarm for a period of ten minutes.

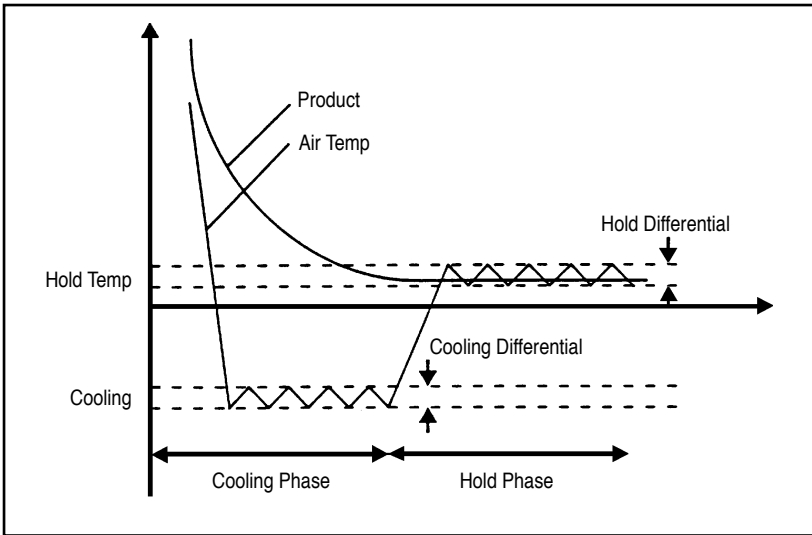

### Internal Overtemperature Alarm

Should the internal temperature of the coldroom rise above +80°C, possibly due to a defrost heater malfunction, the Overtemperature Alarm LED will flash red and the alarm will sound. Also at this point, all other outputs will fall low (condensing control). The Controller will remain in this state until the cause of the alarm is removed i.e. until the coldroom internal temperature falls below +80°C or power is disconnected from the Controller.

## 2.2 TEMPERATURE CONTROLLER OPERATION

When a preset programme is initiated, the controller will enter the Cooling Phase and cause the air temperature within the coldroom to fall dramatically in order to rapidly chill or freeze the stored product. The duration of the Cooling Phase may be controlled in two ways; through actual product temperature measurement using the Food Probe or by setting a fixed Cooling Time. Upon completion of the Cooling Phase the Controller will enter the Hold Phase and the air temperature within the coldroom will rise in order to prevent further chilling or freezing and hold the product at the desired storage temperature.

### 2.2.1 Defrosting

The controller will perform automatic defrosting every six hours after a programme is initiated. Defrosting of the evaporator coil will occur for a period of ten minutes or until the coil has reached a temperature of +30°C after which moisture from the coil is allowed to drain away for a further two minutes. During this period DEF will be shown in the Temp Display. Following this period the refrigeration cycle will recommence and REC (Recovery) will be shown in the Temp Display for a period of five minutes or until the evaporator coil cools to -5°C at which point the evaporator fans will also re-start. The Temp Display will now revert to showing air temperature. Defrosting may be manually initiated while the controller is in standby (before starting a programme) or during the Hold Phase by holding down the '0,0' key and pressing the '7/0' key. See Operation Flowchart.

### 2.2.1. ALARM FUNCTIONS

The Food Temperature and Hold Alarms may be cancelled by operation of the fascia panel Alarm Mute Key. The internal Overtemperature Alarm can only be cancelled by resetting the Controller or removing the cause of the alarm.

**Hold Alarm** - The Controller alarm output will sound on entry to the Hold Phase to indicate completion of the Chill Phase. The Hold Alarm will sound for a period of two minutes. Alternatively, the Hold Alarm may be muted by operation of the 'X' key.

**Food Temperature** - The Controller calculates the temperature of the stored product during the Hold Phase through monitoring internal air temperature. Should the calculated stored product fall outside the preset alarm limits, the Food Temperature LED will illuminate amber and the alarm will sound. Should the stored product fall back within the limits, the Food Temperature LED will extinguish and the alarm will cease. The Food Temperature Alarm may be temporarily cancelled by operation of the 'X' key. This will mute the alarm for a period of ten minutes. If after the ten minute period, the calculated food temperature is still outside the preset alarm limits, the alarm will sound again.

### 2.2.3 ADDITIONAL FEATURES

**Surface Protection** - To minimise surface damage to delicate products the surface protection function raises the air temperature during the latter part of the Cooling Phase. The air temperature during the Cooling Phase while Surface Protection is active, rises to -2°C. Under a Cooling Time Control Program, Surface Protection becomes active after 70% of the pre-set cooling time has elapsed. Under a Food Temperature Control Program, Surface Protection becomes active when +5°C, measured by the Food Probe is reached. Surface Protection cannot be selected if the program setting; Food temperature, Cooling temperature or Holding Air temperature are below -15°C.

**Cooling Program Extension** - During the Hold Phase following a Cooling Time Program, the Controller can be caused to re-enter the Cooling Phase for a further ten minutes. Program Extension can be initiated by holding down the 'SET' key and pressing the 'TEMP/TIME' key.

**Capacity Control** - The function of the Capacity Control output is to reduce the refrigeration capacity of the condensing unit during periods when the required internal air temperature is above a set value. Capacity Control is achieved by unloading one cylinder of a multi-cylinder compressor by means of a solenoid valve disabling a condenser fan on systems having multiple condenser and by means of a contactor. The Capacity Control output will be made when the set internal air temperature during the Cooling or Hold Phase is above the value of the Capacity Control Limit on parameter No.P24.

## 2.3 OPERATION FLOWCHART

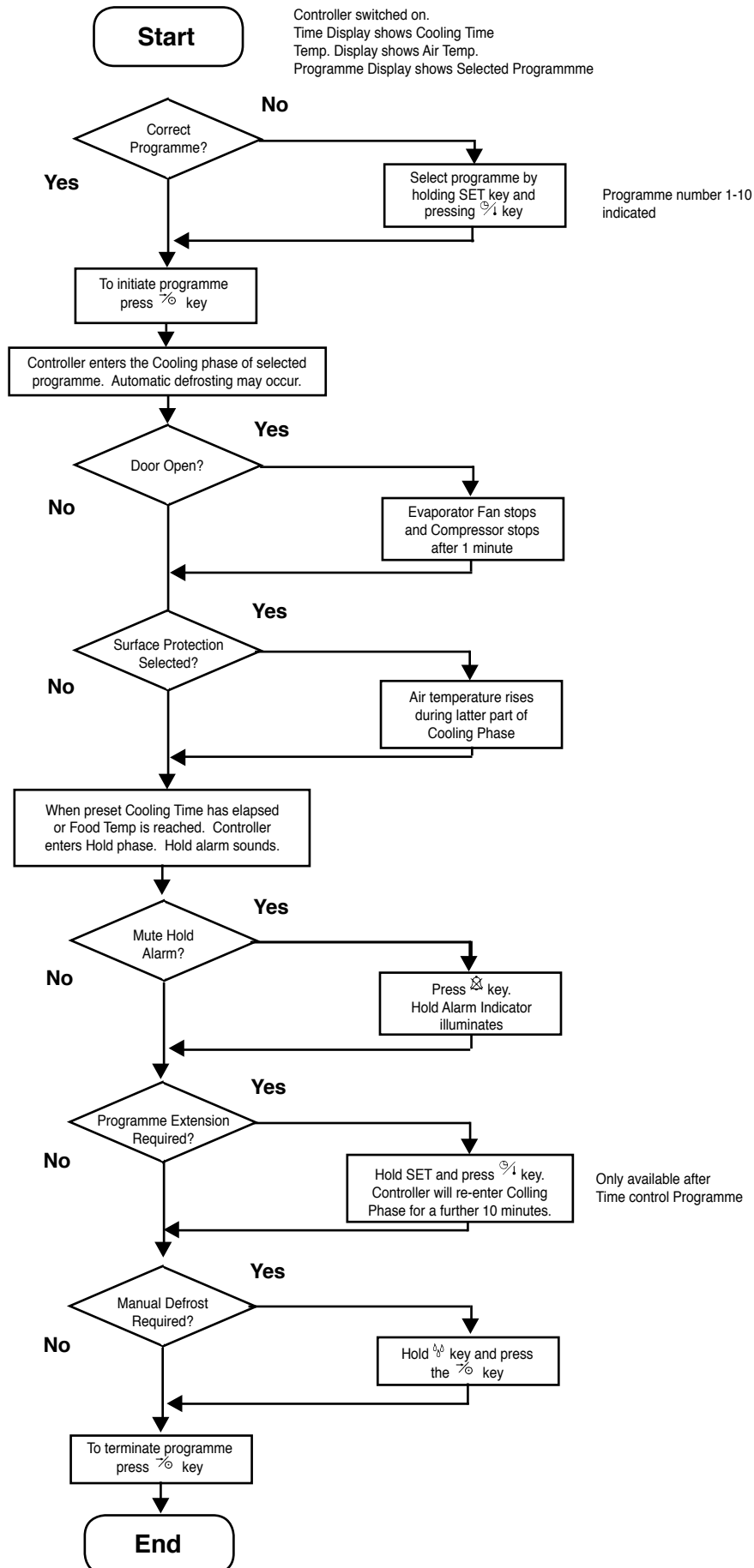

## 2.4 PROGRAMME SETTING FLOWCHART

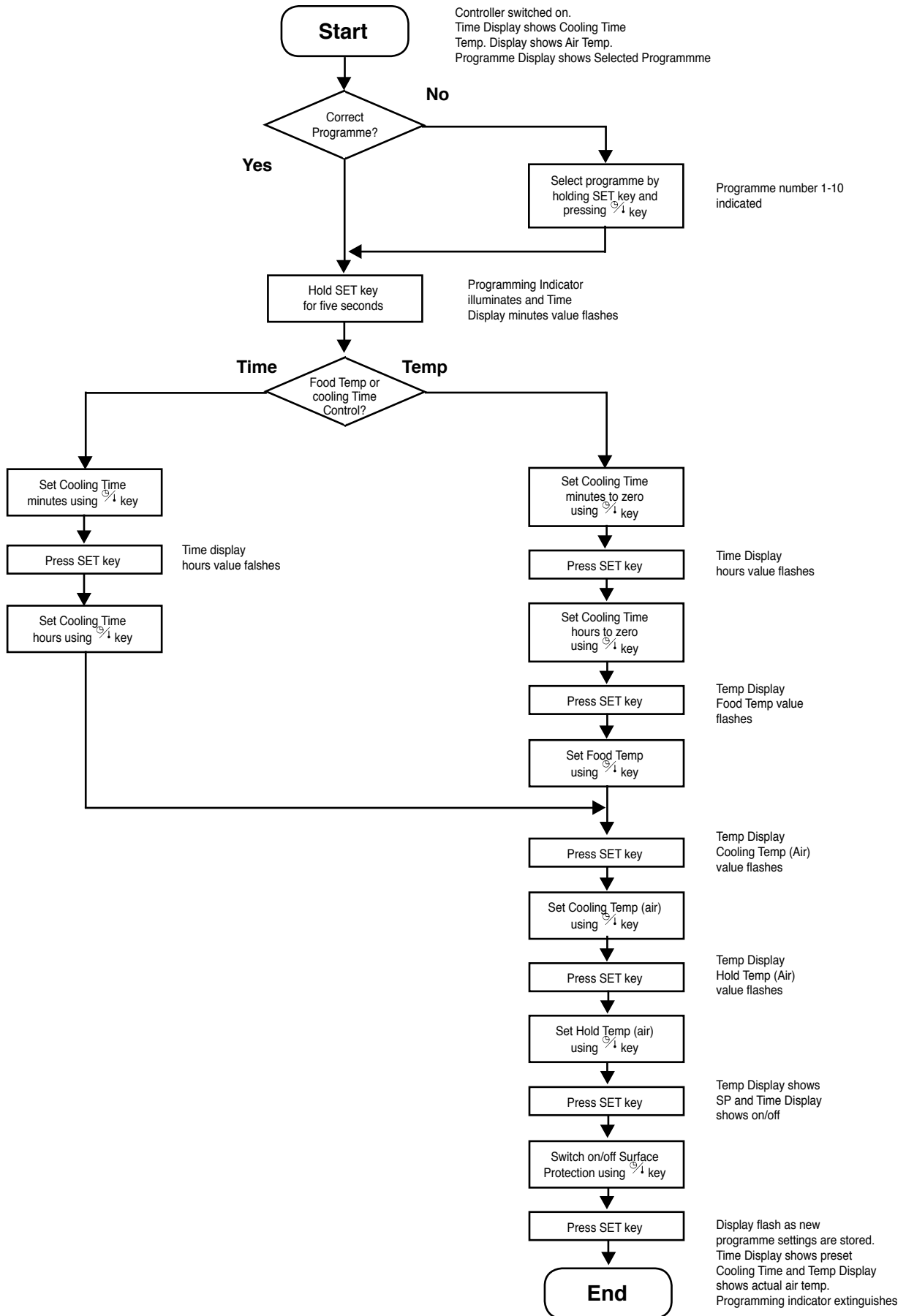

## 2.5 USING THE BLAST CHILLER/FREEZER

### 2.5.1 Cleaning and Maintenance

- High Pressure washers may damage the seal between coldroom panels and possibly create electrical hazards and must not be used to clean the exterior or interior of the Blast Chiller/Freezer room.
- Alkaline based cleaning agents (bleach), solvents and cleaners containing abrasives will damage the surfaces of the room and must be avoided.
- A solution of warm water and mild detergent is recommended followed by rinsing and drying.

### 2.5.2 Good Practice Guidelines

- Hot products exceeding +70°C should not be placed in the Blast Chiller/Freezer. A good indication is when steam has stopped rising.
- Pre-chilling the unit will reduce the chilling/freezing time.
- Allow meat/poultry cuts to rest after cooking and before chilling/freezing.
- Do not fill containers to a depth of over 50mm (2").
- Do not overload the mobile trolley, leave a 50mm (2") gap between each container.
- Always ensure the food probe is cleaned with a sanitised wipe before use.
- Preferably decant sauces and soups out of cooking pots and into shallow Gastronorm containers before chilling.
- Do not place lids or covers over food products during chilling/freezing.

### 2.5.3 Factors Affecting Speed of Chilling/Freezing

- Reducing the temperature within the Blast Chiller/Freezer will speed up the chilling/freezing process. However, when Blast Chilling care should be taken not to freeze the stored product.
- Container shape, and weight will affect chilling/freezing time. In general, increasing the surface area and reducing the weight of the container will reduce the chilling/freezing time.
- Foods of low density and evenly distributed will in general take less time to chill/freeze.
- Foods having low thermal conductivity or high heat capacity will in general take longer to chill/freeze.
- Lids or covers on food containers will cause chilling/freezing times to increase by at least 10%.
- reducing the depth of the food will reduce the chilling/freezing time.
- Increased spacing between each container will reduce the chilling/freezing time.

## 2.6 STANDARD CONTROLLER PROGRAMME SETTINGS

### 2.6.1 Blast Chiller

|                             | Cooling Time        | Food Probe Temp (°C) | Cooling Air Temp (°C) | Hold Air Temp (°C) | Surface Protection |
|-----------------------------|---------------------|----------------------|-----------------------|--------------------|--------------------|
| Programme 1                 | 1 hr 30 mins        | N/A                  | -10                   | +3                 | OFF                |
| Programme 2                 | 0 hr 0 mins         | +3                   | -10                   | +3                 | OFF                |
| Programme 3                 | 1 hr 30 mins        | N/A                  | -10                   | +3                 | ON                 |
| Programme 4<br>Programme 10 | <b>UNPROGRAMMED</b> |                      |                       |                    |                    |

### 2.6.2 Blast Freezer

|                             | Cooling Time        | Food Probe Temp (°C) | Cooling Air Temp (°C) | Hold Air Temp (°C) | Surface Protection |
|-----------------------------|---------------------|----------------------|-----------------------|--------------------|--------------------|
| Programme 1                 | 1 hr 30 mins        | N/A                  | -35                   | -21                | OFF                |
| Programme 2                 | 3 hr 0 mins         | N/A                  | -35                   | -21                | OFF                |
| Programme 3                 | 4 hr 30 mins        | N/A                  | -35                   | -21                | OFF                |
| Programme 4<br>Programme 10 | <b>UNPROGRAMMED</b> |                      |                       |                    |                    |

## 2.7 ELECTRICAL CONNECTIONS

2.7.1 **Electrical Connections** - For connections to rear of Controllers - see Fig 3 below and page 29.

|                     |   |
|---------------------|---|
| ● Supply:           | 1 Live (L1), 1 Neutral (N1), 1 Earth (E). |
| ● Condenser:        | 1 Live (C)                                |
| ● Evaporator Fans:  | 2 Live (F)                                |
| ● Capacity Control: | 1 Live (CAP)                              |
| ● Defrost:          | 2 Live (D)                                |
| ● Alarm:            | 1 Live (AL)                               |
| ● Common Neutral:   | 7 Neutral (N)                             |
| ● Food Probe-1      | 2 Screw Terminals (PRB1)                  |
| ● Air Probe:        | 2 Screw Terminals (PRB2)                  |
| ● Evaporator Probe: | 2 Screw Terminals (PRB3)                  |
| ● Safety Probe:     | 2 Screw Terminals (PRB4)                  |
| ● Food Probe-2:     | 2 Screw Terminals (PRB5)                  |
| ● Food Probe-3:     | 2 Screw Terminals (PRB6)                  |
| ● Door Switch:      | 2 Screw Terminals (DOORSW)                |

**Blast Chiller Controller Terminal Arrangement**

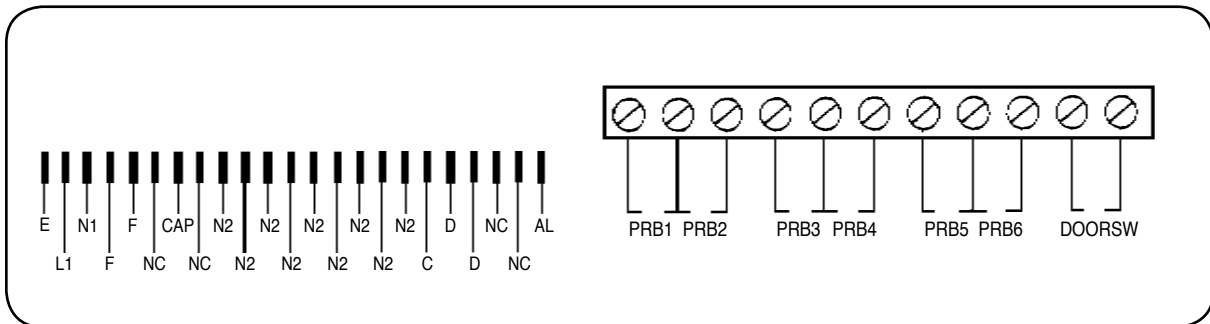

**Figure 3**

**Connections to rear of Controller**

## 2.8 DISPLAY FASCIA PANEL







2.8.1 **Display Fascia Panel (see Fig 4 Page 19)**

Construction - Fitting of the fascia panel to the Counter or Cabinet sheet metal unit cover is by means of a screw and boss fitting.







2.8.2 **Ratings** - An 'O' ring provides sealing between the cover and Fascia panel. The front of the Fascia Panel has a protection classification of IP54 and the material used is a fire retardant and self extinguishing.

2.8.3 **Symbols and Indicators** - The displays on the fascia panel consist of a smoked seven digit seven segment display together with the following indicators and symbols.

2.8.4 **Illuminated Indicators** - These appear adjacent to the three digit seven segment display.

- Condensing unit -  LED illuminated green when Condensing Unit output is high.
- Evaporator Fans -  LED illuminated green when Evaporator Fan output is high.
- Food Temperature -  LED illuminated amber when Calculated Stored Product Temp. is outside the preset High and Low Food Temperature Alarm Settings (11 and 12 respectively).
- Overtemperature -  LED flashing red in the event of the Alarm Internal temperature exceeding the preset Overtemperature Alarm Setting (14).
- Food Control Chill -  LED illuminated green prior to and during the Cooling Phase of a Food Temperature Control Program.
- Time Control Chill -  LED illuminated green prior to and during the Cooling Phase of a Cooling Time Control Program.
- Hold -  LED illuminated green during the Hold Phase.
- Programme number display - displays current programme number.
- Run - LED illuminated green during program operation.
- Programming - LED illuminated during programming procedure.
- Hold Alarm - LED illuminated green after Hold Alarm is muted.

2.8.5 **Key Symbols**

-  Switches the Controller between 'Sleep' and 'on' states.
-  Starts or stops a selected Controller Program.
- **SET** Used to enter programming sequence and acknowledge program settings.
-  Used to alter time or temperature values during programming sequence.
-  Used in conjunction with the  key to indicate a manual defrost.
-  Will mute the audible Hold Alarm permanently or the Food Temperature Alarm for a period of ten minutes.

## 2.9 OPERATION

In this section the behaviour of the Controller is described in the form of a list of events (Event/response list) with regard to the cold room refrigeration components.

### 2.9.1 Refrigeration and Defrost.

2.9.2 **Power Connected to Cold Room** - The Controller is in a 'sleep' mode, three bars are displayed on the fascia panel, all outputs are in a low state.

2.9.3 **'I/O' Key Depressed** - The Controller switches on, fascia panel indicates program time and internal air temperature. Any one of ten stored programs may be selected. Program settings may also be altered.

2.9.4 **Start/Stop Key Depressed** - The selected Controller is indicated.

2.9.5 **Chill Phase** - If the selected program is a Food Temperature Control Program, the following sequence of events will occur - (See list of Control parameters, Page 9 and 10).

The fascia panel displays **Chill Time (set to zero) & Food Temp.** (measured by Food Probe 1). The Evaporator fan output goes high and the refrigeration cycle begins. The Chill Time displayed on the fascia panel will increment from zero. If internal Air Temp is higher than the preset Air Temperature plus Chill Temperature Differential (1) the Condensing Unit output goes high.

When the internal air temperature pulls down to the preset Air Temperature, the Condensing Unit output goes low. This Chill Phase continues until the preset Food Temperature is reached. The displayed Chill Time stops incrementing & holds the displayed value (Duration of Chill Phase).

Or if the selected program is a Chill Time Control program, the following sequence of events occurs.

The fascia panel displays Chill Time and Air Temperature. The evaporator fan output goes high and the refrigeration cycle begins. The Chill Time displayed on the fascia panel will decrement from the programmed value. If the internal air temperature is higher than the preset Air Temp plus Chill Temperature Differential (1) the Condensing Unit output goes high. When the internal air temperature pulls down to the preset Air Temperature, the Condensing Unit output goes low. This Chill Phase continues until the displayed time decrements to zero.

2.9.6 **Hold Phase** - The Hold Alarm output goes high to indicate completion of the Chill Phase. With the evaporator fan output still high, the condensing unit output falls low until the internal air temperature rises to the preset Hold Temperature plus Hold Temperature Differential (2).

The condensing unit output goes high until the internal air temperature pulls down to the preset Hold Temperature.

The Hold Phase continues until the program is stopped by operation of the start/stop key.

## 2.10 SURROUNDINGS AND EXTERNAL INFLUENCES

### 2.10.1 Inputs

- **Food Temp Probe-1**

Senses stored product temperature. Used for control.

Negative temperature/resistance coefficient thermistor probe.

- **Air Temp Probe**

Senses internal air temperature.

Negative temperature/resistance coefficient thermistor probe.

- **Evap Temp Probe**

Senses temperature at the evaporator coil, required to terminate defrost.

Negative temperature/resistance coefficient thermistor probe.

- **Safety Probe**

Senses temperature at the evaporator coil in order to detect an internal overtemperature.

High temperature, Negative temperature/resistance coefficient thermistor probe.

- **Food Temp Probe-2**

Senses stored product temperature. Optional, used for indication only.

Negative temperature/resistance coefficient thermistor probe.

- **Food Temp Probe-3**

Senses stored product temperature. Optional, used for indication only.

Negative temperature/resistance coefficient thermistor probe.

- **Door Switch**

Voltage free contacts, open circuit when door is open causing evaporator fan output to fall low and condensing unit output to fall low after a period of one minute.

- **Display Fascia**

Used to switch On/Off the Controller.

Initiate or terminate a Chill or Freeze program.

Program in operating parameters.

Manually initiate a defrost.

Cancel all alarm outputs.

### 2.10.2 Outputs

- **Condensing Unit**

Relay output switching single phase mains supply to condensing unit (compressor and condenser fan). Contact 250 Va.c. 10 A.

- **Evaporator Fan**

Relay output switching single phase mains supply to evaporator fans. Also, in parallel with the evaporator fans are connected the mullion and vaporiser tray heaters. Contact rating 250 Va.c. 10 A.

- **Capacity Control**

Relay output switching single phase mains supply to condenser fan contactor or condensing unit unloading solenoid. Contact rating 250 Va.c. 10 A.

- **Defrost**

Relay output switching single phase mains supply to hot gas solenoid or, electric heaters. Contact rating 250 Va.c. 10 A.

- **External Alarm**

Relay output switching single phase mains supply to alarm, activated when chill phase is completed, when calculated food temperature is outside preset limits (during Hold Phase) and in the event of an internal overtemperature. Contact rating 250 Va.c. 10 A.

- **Display Fascia**

Seven segment display, nine digits.

Normally indicating cabinet air or product temperature & cooling time.

To display parameter values during controller programming .

Status indicatin during defrost.

Indicator LEDs representing current control phase, selected program and status of rigeration component outputs.

## 2.11 PROGRAM SETTING AND CONTROL PARAMETER ADJUSTMENT

2.11.1 The user can tailor the Program Settings to suit the particular product to be chilled. Settings can be saved in up to ten programs, stored by the controller (P01, P02....P10).

Control parameters alter the characteristics of the chilling or freezing process. The Control Parameters should not be adjusted without detailed knowledge of the operation of the Controller.

During the programming of either Program Settings or Control Parameters, if no key is pressed for a period of two minutes, the Controller will exit the particular programming mode without saving any modified settings or parameters.

2.11.2 **Program Setting** - While the Controller is switched on with Chill Time and Food Temperature or Air Temperature displayed on the fascia panel, the required stored program can be selected. While holding down the 'SET' key, pressing the 'Time/Temp' key will change the selected program, indicated in the right hand fascia window by the green LEDs P01, P02 or P10.

- To enter the programming sequence the 'SET' key must be depressed for five seconds, until the green programming LED is illuminated. The Chill Time minutes display will flash and the minutes value may be altered using the 'Time/Temp' key
- Pressing the 'SET' key again will cause the Chill Time hours display to flash, which may be altered using 'Time/Temp' key.
- **Food Temperature Control Program** (Chill Time set to zero) - Pressing the 'SET' key will cause the green Food Control Chill LED to illuminate and the Food Temperature may be altered using the 'Time/Temp' key. Pressing the 'SET' key again causes the green Air Control Cooling LED to illuminate and the Air Temperature may be altered using the 'Time/Temp' key.
- **Chill Time Control Program** (Chill Time set above zero) - Pressing the 'SET' key will cause the green Air Control Cooling LED to illuminate and the Air Temperature may be altered using the 'Time/Temp' key.
- Pressing again the 'SET' key will cause the green Hold LED to illuminate and the Hold Temperature may be altered using the 'Time/Temp' key.
- Pressing again the 'SET' key will cause SP (Surface Protection) to be displayed in the left hand window of the fascia panel. Surface Protection can be selected using the 'Time/Temp' key and On or Off is displayed in the right hand window of the fascia panel display.
- Pressing again the 'SET' key will save the program settings and the fascia panel display will flash for five seconds (indicating storage of program settings). The green Programming LED will extinguish and the Controller will exit the programming mode.

1.11.3 **Control Parameters** - Are accessed while the Controller is in the 'sleep' state with nine bars displayed on the fascia panel. While holding down the 'SET' key, pressing the 'I/O' key will cause the fascia panel to display the Control Parameter number in the left hand window and the Control Parameter value in the centre window. The control parameter may be altered (within its limits) by operation of the 'Time/Temp' key. Pressing the 'SET' key causes the display to advance to the next Control Parameter.

- To exit and save the new Control Parameter values, the 'Start/Stop' key must be pressed. The Controller reverts to the 'on' state.
- To exit without saving the new Control Parameter values, the 'I/O' key must be pressed. The Controller reverts to the 'sleep' state.

## 2.12 PROGRAM AND CONTROL PARAMETER SETTINGS

2.12.1 **Program Settings**

- **Chill Time (Mins)** - Duration of Chill Phase for a Chill Time Control Program. If set to zero, the Controller automatically assumes a Food Temperature Control Program.
- **Food Temperature (°C)** - Desired Food Temperature at completion of the Chill Phase. Required when a Food Temperature Control Program is selected. Measured by the Food Probe inserted into the product to be cooled.
- **Chill Air Temp. (°C)** - Cold Room internal Air Temperature during the Cooling Phase.
- **Hold Air Temperature (°C)** - Cold Room internal Air Temperature during the Hold Phase.
- **Surface Protection (On/Off)** - Selects Surface Protection function which raises the Air Temperature during the latter part of the Chill Phase. Surface Protection can only be selected if the program Settings - Food, Chill Air & Hold Air Temperature are above the value Surface Protection (23).

2.12.2 **Control parameters - Fixed or Programmable (F or P)**

| No. | F or P | Description  | Settings (Limits) |
|-----|--------|--|-------------------|
| 1   | P      | <b>Cooling Temperature Differential (°C)</b><br>Chill Set Point + Chill Temperature Differential = High point of Chill operating range.  | 3 (1 to 10)       |
| 2   | P      | <b>Hold Temperature Differential (°C)</b><br>Hold Set Point + Hold Temperature Differential + High point of Hold operating range.  | 3 (1 to 10)       |
| 3   | P      | <b>Compressor Rest Time (Mins)</b><br>Minimum Time between successive compressor operations  | 0 (0 to 10)       |
| 4   | P      | <b>Defrost Termination Temperature (°C)</b><br>Evaporator Probe Temperature at which defrost terminates  | 30 (0 to +50)     |
| 5   | P      | <b>Defrost Termination Time (Mins)</b><br>Maximum defrost time duration  | 10 (0 to 30)      |
| 6   | P      | <b>Number of Defrosts Per Day</b><br>Determines duration between automatic defrosts  | 4 (0 to 24)       |
| 7   | P      | <b>Defrost Type (1/0)</b><br>Hot Gas (1) or Electric (0), determines whether both the defrost and condensing unit outputs or the defrost output alone goes high when a defrost is initiated. | 0 (1 to 0)        |
| 8   | P      | <b>Drain Down Time (Mins)</b><br>Time period after defrost for which the Defrost and Condensing Unit outputs remain low.   | 2 (0 to 10)       |
| 9   | P      | <b>Fan Delay Time (Mins)</b><br>After Drain down period, time for which Evaporator Fan output remains low.   | 5 (0 to 10)       |
| 10  | P      | <b>Fan Delay Temperature (°C)</b><br>After Drain down period, Evaporator Fan output remains low until the Fan Delay Temperature measured by the evaporator probe is reached                  | -5 (-10 to 10)    |
| 11  | P      | <b>High Food Temperature Alarm (°C)</b><br>Value added to High Point of Hold Operating Range (Hold Set Point plus Hold Differential)   | 5 (1 to 20)       |
| 12  | P      | <b>Low Food Temperature Alarm (°C)</b><br>Value to be subtracted from Low Point of Hold operating range (Hold Set Point)   | 5 (1 to 20)       |



| No. | F or P | Description  | Settings (Limits) |
|-----|--------|--|-------------------|
| 13  | P      | <b>Hold Alarm Duration (Mins)</b><br>Maximum duration of Hold Alarm  | 2 (0 to 999)      |
| 14  | P      | <b>Internal overtemperature Alarm Setting ( °C)</b>  | 80 (50 to 120)    |
| 15  | P      | <b>Chill/Freeze Select (I/O)</b><br>Freeze (1) or Chill (0) Configures operation as a Chiller or Freezer   | 0 (0 to 1)        |
| 16  | F      | <b>Maximum Chill Set Point (°C)</b><br>Maximum allowable Chill Temperature Set Point Active when Chiller Operation is selected<br>(Parameter 15 = 0)   | 10                |
| 17  | F      | <b>Minimum Chill Set Point (°C)</b><br>Minimum allowable Chill Temperature Set Point Active when Blast Chiller Operation is selected<br>(Parameter 15 = 0)   | 10                |
| 18  | F      | <b>Maximum Freeze Cooling Set Point (°C)</b><br>Maximum allowable Freeze Temperature Set Point Active when Freeze Operation is selected<br>(Parameter 15=1)  | 10                |
| 19  | F      | <b>Minimum Freeze Cooling Set Point (°C)</b><br>Minimum allowable Freeze Temperature Set Point Active when Freeze Operation is selected<br>(Parameter 15=1)  | -35               |
| 20  | P      | <b>Surface Protection Temperature (°C)</b><br>Air Temperature Set Point during Chill Phase when Surface Protection Temperature (°C)  | -2 (-25 to 5)     |
| 21  | P      | <b>Surface Protection Time (%)</b><br>Under a Chill Time Control program, the percentage of Chill Time after which the Air Temperature Set Point rises to the value Surface Protection Temperature (20)                            | 70 (0 to 100)     |
| 22  | P      | <b>Surface Protection Food Temperature (°C)</b><br>Under a Food Temperature Control program, the measured Food Temperature at which the Air temperature Set Point rises to the value Surface Protection Temperature (20)           | 5 (-10 to +30)    |
| 23  | P      | <b>Surface Protection Limit (°C)</b><br>If the programmed Food Temperature (under a Food Temperature Control Program) Air Temperature or Hold Temperature are above this value, the Surface Protection function cannot be selected | -15 (-15 to 5)    |
| 24  | P      | <b>Capacity Control Limit (°C)</b><br>The output is high during the Chill or Hold Phase if the Set point is above this value   | 0 (-15 to 5)      |

## 2.13 ERROR ANNUNCIATION AND FAULT FINDING

### 2.13.1 Error Annunciation

Should a temperature probe failure occur, the controller will indicate the fault by flashing PF followed by the probe number.

- The Controller may be fitted with up to three food probes, an air probe, an evaporator coil probe and an overtemperature safety probe.
- The first food probe is used for control and must be fitted.
- The second and third food probes are used for indication only and need not be fitted. Probe fault will not occur if Food Probe 2 or Food probe 3 if damaged or disconnected. Probe failures are shown on the fascia panel as follows:

**PF1** Food Temperature Probe (1) fault.

**PF2** Air Temperature Probe fault.

**PF3** Evaporator Temperature Probe fault.

**PF4** Safety Temperature Probe fault.

2.13.2 **PF1 Probe Fault** - If a probe fault occurs during a Food Temperature Control Program, the Condensing unit Output will fall low.

If a food probe fault occurs during a Chill Time Control program, the Controller will continue to operate normally.

- **PF2** - If an air probe fault occurs during either a Food temperature or Chill Time Control program, the condensing unit output will fall low.
- **PF3** - If an evaporator probe fault occurs, the parameter defrost Termination Temperature (4) is ignored & defrosts are caused to terminate only after the period Defrost Termination Time (5) has elapsed.
- **PF4** - If a safety probe fault occurs, all Blast Chiller Controller outputs will fall low - the overtemp alarm will not sound.

2.13.3 **Fault Finding** - Before any checks are made to controller operation and the rear cover of the controller is removed, power **MUST BE** disconnected from the Cold Room.

### 2.13.4 Compressor and/or Evaporator Fan(s) not working

Check operation of door switch(es). Door switches are of reed switch type which should be closed-circuit when door is closed (with switch adjacent to the magnet) and open-circuit when door is open (with switch away from the magnet). Check switch operation by connecting a circuit tester across the switch outputs, when switch is disconnected from the Controller board.

### 2.13.5 Probe Fault - PF1, PF2, PF3 or PF4

- A probe fault occurs when the controller is unable to read the temperature probe. Firstly, check the integrity of the probe connections to the controller board.
- Check the resistance of the temperature probe with the probe disconnected from the controller board, using an ohm meter. The temperature probes used are of the thermistor type, which change in resistance when subjected to a change in temperature. As temperature is seen to rise, the resistance of the probe should fall.

2.13.6 For probes 1, 2 and 3 (Food, Air and Coil) Probe Fault occurs if a resistance corresponding to above +60°C or below -60°C (approximate values) is detected. See the following temperature resistance values.

|       |           |       |           |       |             |
|-------|-----------|-------|-----------|-------|-------------|
| +60°C | 656 ohms  | +10°C | 3448 ohms | -20°C | 12100 ohms  |
| +30°C | 1679 ohms | 0     | 5107 ohms | -30°C | 19455 ohms  |
| +20°C | 2381 ohms | -10°C | 7754 ohms | -60°C | 100181 ohms |

2.13.7 For probes 4 (Overtemp) Probe Fault occurs if a resistance corresponding to above +204°C or below +30°C (approximate values) is detected. See the following temperature resistance values.

|        |           |        |            |       |             |
|--------|-----------|--------|------------|-------|-------------|
| +204°C | 589 ohms  | +100°C | 6786 ohms  | +40°C | 53248 ohms  |
| +160°C | 1465 ohms | +80    | 12552 ohms | +20°C | 124936 ohms |
| +120°C | 3886 ohms | +60°C  | 24871 ohms | +3°C  | 280542 ohms |

- Note - The Controller 'ignores' the Overtemp Probe below an evaporator coil temperature of +25°C (measured by the Evaporator Probe).

## 2.14 CONTROLLER DETAIL

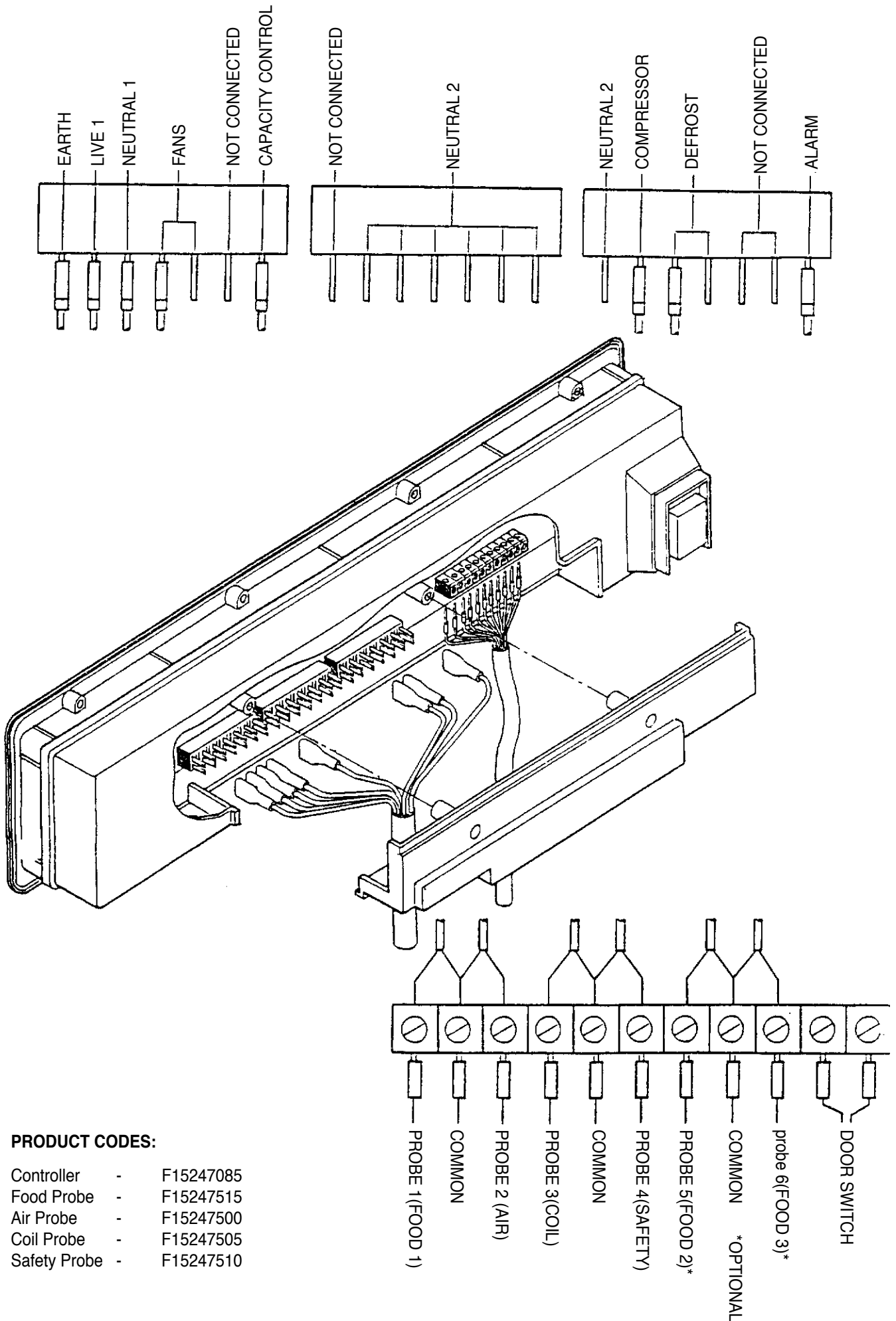

### PRODUCT CODES:

|              |   |           |
|--------------|---|-----------|
| Controller   | - | F15247085 |
| Food Probe   | - | F15247515 |
| Air Probe    | - | F15247500 |
| Coil Probe   | - | F15247505 |
| Safety Probe | - | F15247510 |

## 2.15 FOOD PROBE DETAIL

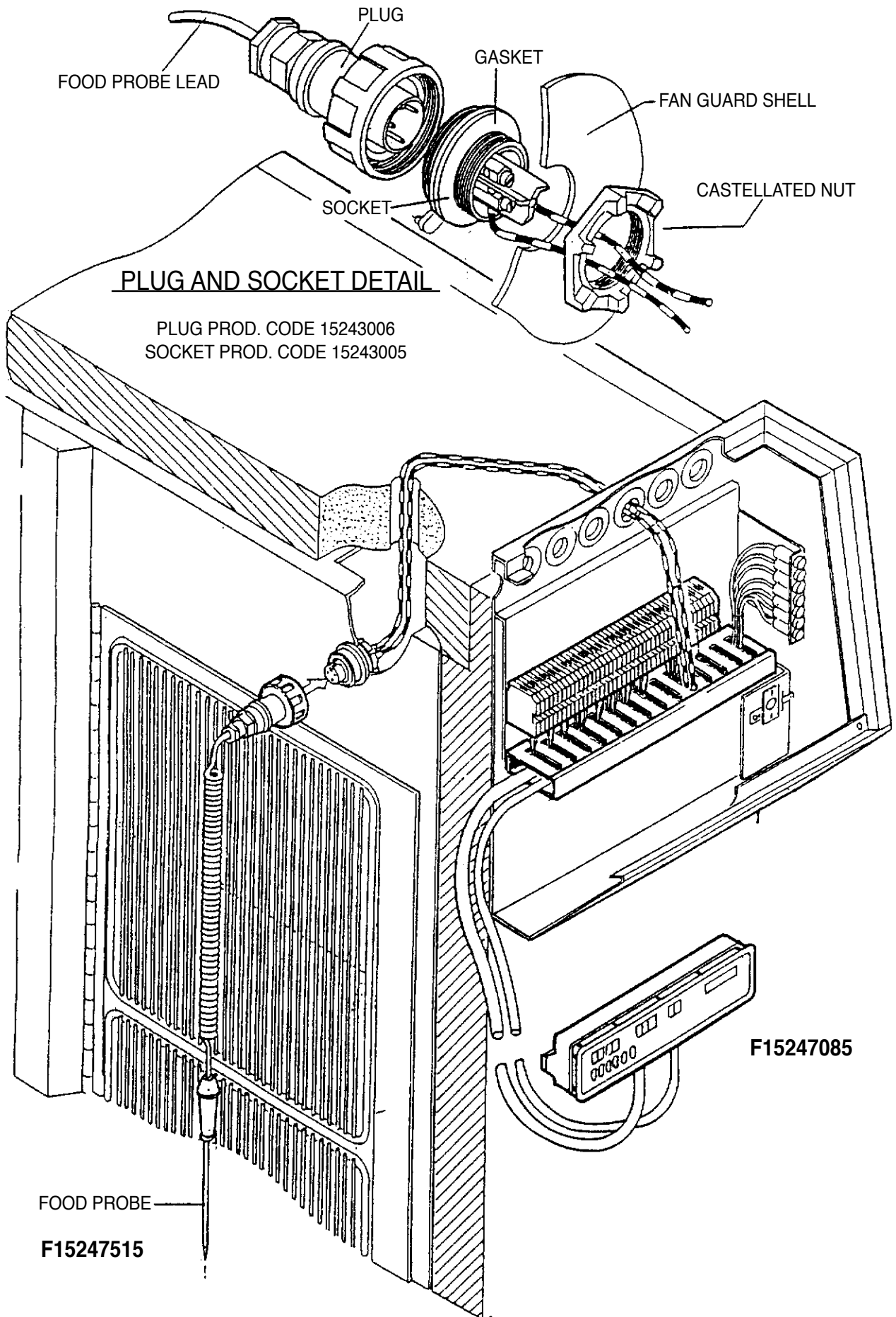

# 3.3 MODULAR BLAST CHILLERS & FREEZERS

MK 1 Control Panel Up To February 1997

## 3.0 BLAST CHILLER

### 3.1 INTRODUCTION

The Blast Chiller is an essential component in the Chill chain process of food production.

Advanced food preparation is more common in today's catering operations allowing cooking staff to plan ahead and reduce the working days peaks and troughs.

Food cooked in advance and stored must be cooled quickly to minimise bacterial growth. Rapid chilling enables the food core temperature to pass through the temperature danger zone (+70 to +3°C) in the shortest time. Within the +70 to +3°C temperature range the bacteria population will double every 10 minutes.

The product can then be stored prior to use for up to 5 days in a storage refrigerator at a temperature below 3°C, without loss or deterioration in colour, texture and flavour.

The new Foster Modular Blast Chiller's are designed to meet this need with the large scale operator in mind. Both oven and chilling trolleys can be accommodated in both roll-in and roll-through configuration. This minimises double handling and decreases the food processing time.

The Blast Chiller has been designed with caterers in mind, providing a flexible chilling unit with easy to use controls and improved access for cleaning and maintenance.

### 3.2 CONTROLLER - INTRODUCTION

The purpose of the Blast Chiller is to reduce the temperature of cooked product within a pre-determined time period.

The complex nature of food products means that the optimum chilling process will vary with differing food types.

The Blast Chiller control system has been designed to give the user an interface that is both easy to use and can chill the product to their specification quickly and efficiently.

To achieve this the control system has been configured to provide the facility for ten user definable chill programmes which remain resident in the control system at all times.

In programming the control system, within each of the ten programmes the user can select one of two chilling methods, namely control of the chilling operation by time or secondly by the food core temperature using the food probe.

Once the chilling method has been selected the user defines the temperature and time constraints to finish the program.

This information is saved against the relevant program number and simply called up and initiated by the operator as required.

A facility new to this control system is Surface Protection. To minimise the effects of surface damage on delicate products, Surface Protection limits the temperature of the latter part of the chill cycle to -2°C.

The manual has been written to encompass all aspects of the control system. It opens with a brief illustration of how the Blast Chiller is designed to operate, and follows with an in-depth explanation of operating, programming and testing the controller.

#### 3.2.1 Blast Chiller Operation

To give a full understanding of how the Blast Chiller operates the chill cycle has been broken into three phases. This is explained below and on the following graphs.

- **Phase 1 - Uncontrolled Chill.**

This is the uncontrolled chill phase. To achieve maximum heat transfer from the product in the early part of the chill cycle the unit cools down as rapidly as possible to approximately -15°C.

- **Phase 2 - Controlled Chilling.**

The Air temperature now cycles around the pre-defined air temperature. (this will be affected by Surface Protection if selected). This will continue until:

- Under air temperature control the predefined chill period has elapsed.
- Under probe temperature control the predefined product core temperature has been reached.

- **Phase 3 - Hold**

Once the probe temperature has been reached for a probe control program or when the time reaches zero for a timed air control program, the controller will enter the hold mode.

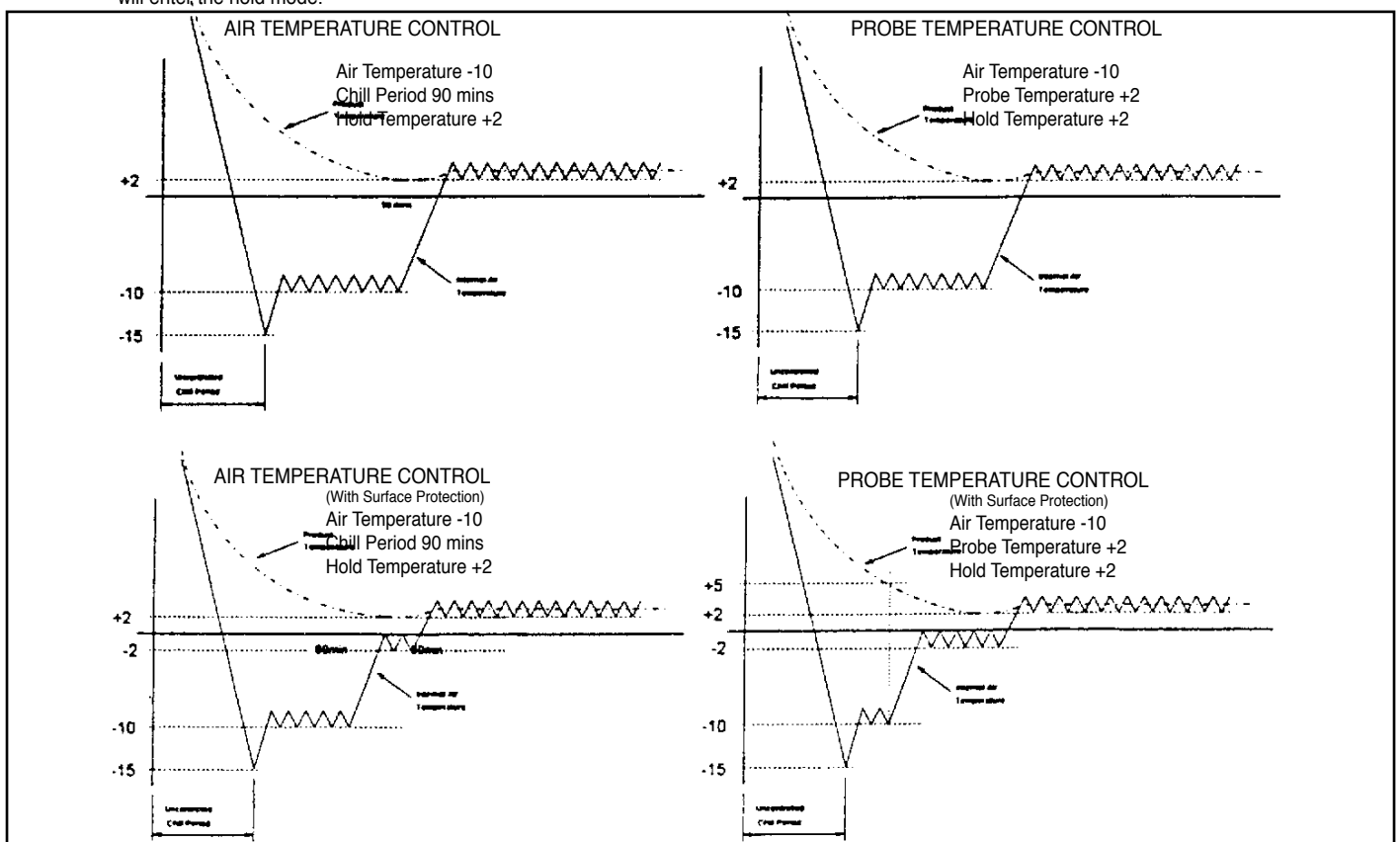

### 3.3 CONTROLLER - THE DISPLAY

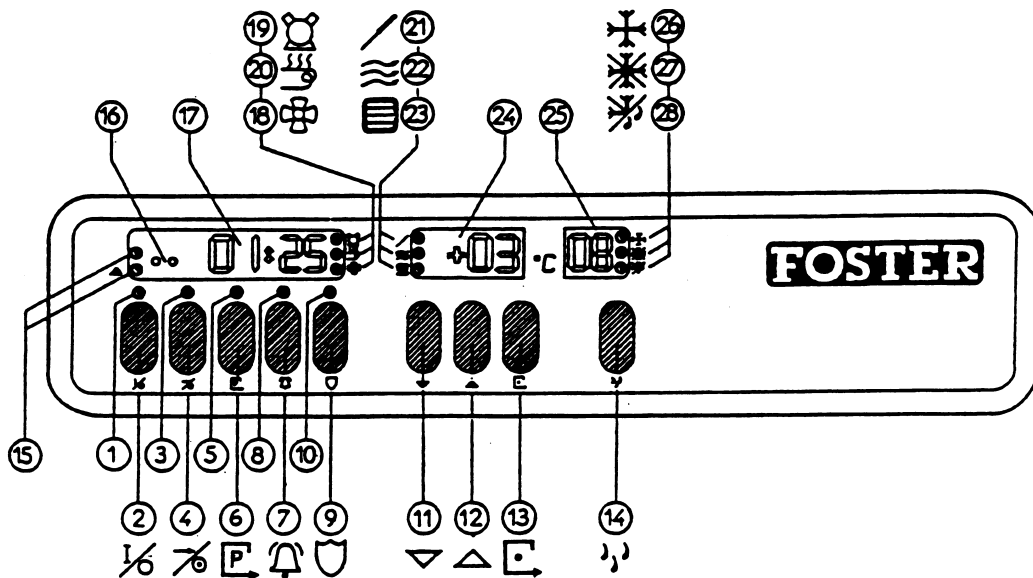

**THE DISPLAY - DIAGRAM 1**



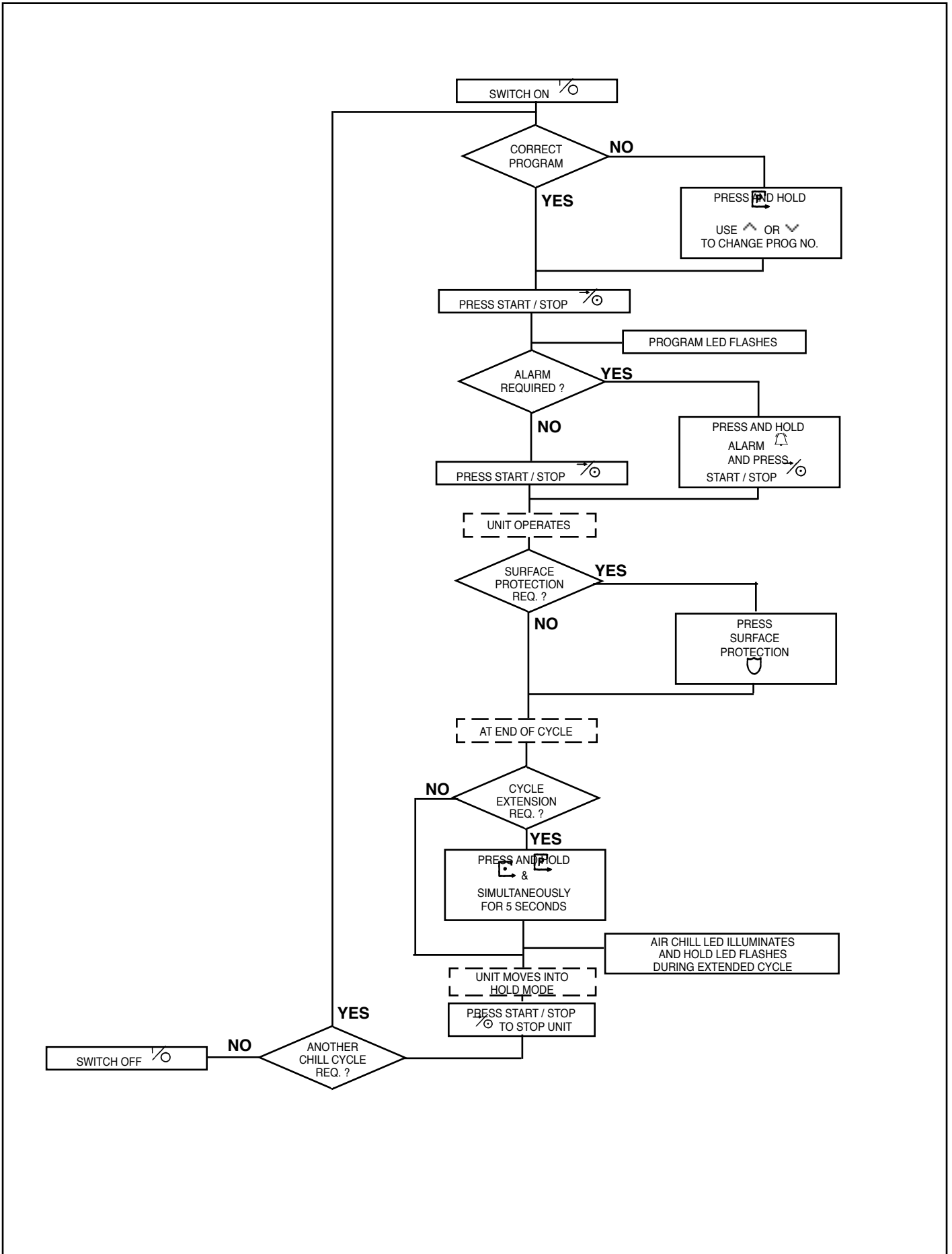

| No. | Symbol | Description  |
|-----|--------|--|
| 1   |        | <b>On LED (Green)</b>  |
| 2   | ⏻      | <b>On/Off</b> - Turns the control system functions on or off. When Off (standby mode) the FOSTER logo is illuminated and three bars are present in display 17 to indicate that power is still supplied to the chiller unit. When On the selected program is displayed. |
| 3   |        | <b>Run LED (Green)</b> - Indicates a program is running  |
| 4   | ⏻      | <b>Start/Stop Button</b> - Start or Stop the program.  |
| 5   | P      | <b>Program LED (Red)</b> - Illuminated when in programming mode.   |
| 6   |        | <b>Program Button</b> - Displays pre-programmed values, used to select programmes and in the programming of the controller.  |
| 7   | 🔔      | <b>Alarm Button</b> - Selects alarm facility during cycle start and mutes audible alarm during operation.  |
| 8   |        | <b>Alarm LED (Yellow)</b> - Flashes when the alarm facility is offered during the cycle start. Displays constantly following the mute of the audible alarm to indicate that the alarm has sounded.   |
| 9   | 🛡️     | <b>Surface Protection Button</b> - Selects surface protection.   |
| 10  |        | <b>Surface Protection LED (Yellow)</b> - Flashes when surface protection is available.<br>- Constant when surface protection has been selected.<br>- Blank when surface protection is not available.   |
| 11  | ⏪      | <b>Decrement Button</b> - Used to decrement various parameters.  |
| 12  | ⏩      | <b>Increment Button</b> - Used to increment various parameters.  |
| 13  | ⏏      | <b>Function Button</b> - Only operational on units having more than one mode. ie Chill/Freeze - if the unit is a chiller only this button does not function.   |
| 14  |        | <b>Manual Defrost Button</b> - Used to initiate a defrost cycle.   |
| 15  |        | <b>Product / Internal Overtemp LED's</b> - (Green / Red)<br>• Green LED - Safe operation<br>• Constant Red LED - Product overtemp<br>• Flashing Red LED - Internal overtemp  |
| 16  |        | <b>Infra-Red Link</b> - Where fitted (optional)  |
| 17  |        | <b>Timer Display:</b><br>• Incremental in Probe Control<br>• Decremental in Air Control<br>• 3 bars in standby mode  |
| 18  |        | <b>Fan LED (Red)</b> - Illuminated when fans are running.  |
| 19  |        | <b>Compressor LED (Red)</b> - Illuminated when compressor is running.  |
| 20  |        | <b>Heat LED (Red)</b> - Operational only on THAW model.  |
| 21  |        | <b>Probe Control LED (Yellow)</b> - Illuminates when the unit is chilling under probe control.   |
| 22  |        | <b>Air Control LED (Yellow)</b> - Illuminates when the unit is chilling under air control.   |
| 23  |        | <b>Hold LED (Yellow)</b> - Illuminates when the unit is in hold.   |
| 24  |        | <b>Temperature Display (Green)</b> - Displays temperature values.  |
| 25  |        | <b>Programme Number Display</b> - Displays current programme number.   |
| 26  |        | <b>Chill LED (Red)</b> - Indicates the type of program.  |
| 27  |        | <b>Freeze LED (Red)</b> - Indicates the type of program.   |
| 28  |        | <b>Thaw LED (Red)</b> - Indicates the type of program.   |

### 3.4 CHILLER OPERATION









### 3.5 CONTROLLER – OPERATING INSTRUCTIONS

3.5.1 **Program Selection** - To select the programme number.

- Switch the unit on using the On/Off button 
- Press and hold the program button 
- Use the Decrement/Increment buttons   to select the required program number.





3.5.2 **Running the Chill Cycle**

- Press the Start/Stop Button 
- Both the Run LED **3** and Alarm LED **8** will flash.
- If an end of cycle audible alarm is required press and hold the Alarm button  and press the Start/Stop button , otherwise press the Start/Stop button  once more.
- The unit will now begin cooling.
- The Run LED **3** will illuminate (as will the Alarm LED **8** if selected).
- The Compressor LED **19** and Fan LED **18** will illuminate.
- If it is an Air Control Cycle the timer display **17** will decrement.
- If it is a Probe Control Cycle then the timer display **17** will increment.
- The Surface Protection facility LED **10** will also flash. (see par 3.5.3 below).
- **At the completion of the chill cycle the controller will switch to the hold mode.**
- The hold LED **23** will illuminate and the Alarm LED **8** will flash.
- If selected the audible alarm will sound and may be cancelled by pressing the Alarm button  The alarm LED **7** will remain on constantly to indicate that the alarm has been acknowledged.
- The unit may be left in this mode for as long as is required. The unit will automatically defrost at a preset period.
- Hold Mode can be terminated by pressing the Start/Stop button  The Controller will prepare to repeat the same cycle.
- Note - During the hold phase, the hold temperature value controls the air temperature, even if a probe control programme has been selected.
- Door opening - During the Chilling cycle, opening the coldroom door will cause the internal fans to stop. This does not stop the timer in display **17** - if the door remains open for a period greater than 30 seconds the compressor is also stopped.



3.5.3 **Surface Protection**

- The surface protection LED **10** will be flashing to indicate that this is available. The effect of this is to limit the air temperature to -2°C for the final one-third of an air control program, or when the probe temperature reaches 5°C for a probe control program. If the program time has passed the two-thirds mark, or if the probe temperature is below 5°C, then this option will cease to be available.



3.5.4 **Display of Programmed/Current Values**

- At any time, the pre-defined temperature values can be seen by pressing the program button 
- When the unit is running, the temperature in the display is indicated by the illumination of LED's 21, 22 & 23.
- When in air temperature control the decrement button  displays the current probe temperature (Probe LED **21** is lit).
- When in probe temperature control the decrement button  displays the current air temperature (air control LED **22** is lit).
- Both in air and probe temperature control the coil temperature can be viewed by pressing the increment button  (LED's 21, 22 & 23 are extinguished).

3.5.5 **Manual Program Extension**

- At the end of the chill cycle, further chilling is required, simultaneously press and hold the function button  and program button  for a period of 5 seconds.
- This will extend the chill cycle by 10 minutes.
- The hold LED **23** will flash during this period.

3.5.6 **Manual Defrost**

- The manual defrost facility is only available when the unit is in the On condition but not running.
- To initiate a manual defrost, press and hold the Manual Defrost button  and press Start/Stop. 

3.5.7 **Automatic Defrost**

- When the unit is in the hold mode, the unit will defrost automatically.

### 3.6 CHILLER PROGRAMMING

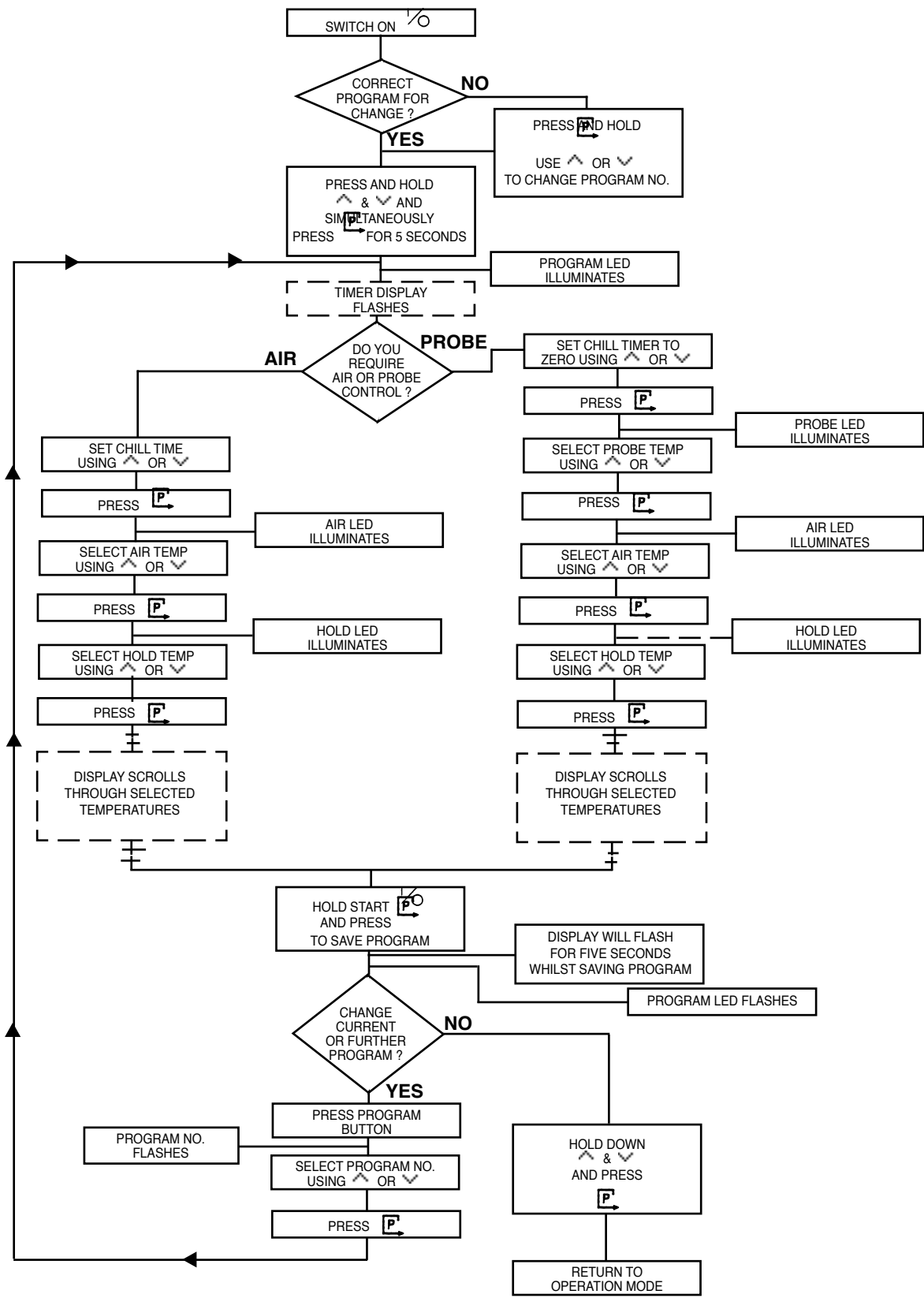



### 3.7 CHILL CYCLE SETTING

- This section covers programming the blast chiller.
- Setting is accessed by simultaneously pressing three buttons to prevent tampering or accidental programming changes. This sequence is as follows:
- 3.7.1 Select the program for change - ref: 3.5.1.
- 3.7.2 Hold down the decrement/increment buttons  $\nabla \Delta$  and simultaneously press the program button  $\text{P}$  until the Program LED illuminates. The controller is now in programming mode. The Timer display will flash.

---

**NOTE: If no changes are made during a programming operation for 2 minutes, the controller will reset itself automatically for normal operation.**

---

- 3.7.3 Set the Timer -
  - a) For Air Temperature Control, use the increment / decrement buttons  $\nabla \Delta$  to select the desired chill time.
  - b) For Probe Temperature Control set the Timer display to zero using the increment / decrement buttons  $\nabla \Delta$
- 3.7.4 For Air Temperature Control - Press the Program button  $\text{P}$ . The Air Control LED 22 will illuminate and the air temperature will flash.
  - Using the increment / decrement buttons  $\nabla \Delta$  select the Air temperature required for chilling.
  - Press the Program button  $\text{P}$  - the Hold LED 23 will illuminate and the hold temperature will flash. Using the increment / decrement buttons  $\nabla \Delta$  select the Hold temperature.
  - Press the Program button  $\text{P}$  - the Temperature Display will alternatively flash between the Air Temperature and the Hold Temperature showing the selected values.  
**Go to 3.7.6**
- 3.7.5 For Probe Temperature Control - Press the Program button  $\text{P}$  .... The Probe Control LED 21 will illuminate and the Probe Temperature will flash. Using the increment / decrement buttons  $\nabla \Delta$  select the desired probe temperature.
  - Press the Program button  $\text{P}$  - the Air Control LED 22 will illuminate and the Air Temperature will flash. Using the increment / decrement buttons  $\nabla \Delta$  select the internal Air Temperature during chilling.
  - Press the Program button  $\text{P}$  - the hold LED will illuminate and the hold temperature will flash. Using the increment / decrement buttons  $\nabla \Delta$  select the desired Hold Temperature.
  - Press the Program button  $\text{P}$  - the temperature display 24 will alternate between probe, air and hold temperature showing the selected values.
- 3.7.6 To save the selected values, press and hold the Start/Stop button  $\text{1/0}$  and press the Program button  $\text{P}$ . All displays will flash for 5 seconds.
- 3.7.7 If the current program has been incorrectly entered or programming of further channels is desired press the Program button  $\text{P}$  - the Program number will flash - display 25. Using the increment / decrement buttons  $\nabla \Delta$  select the Program number to be changed. Press the Program button  $\text{P}$  The Timer display will flash. Continue from 3.7.3
- 3.7.8 To exit the programming mode, hold down the increment / decrement buttons  $\nabla \Delta$ , and press the Program button  $\text{P}$

### 3.8 FAILURE SITUATIONS

- **Power Failure** - In the event of a power failure the unit will stop functioning. On resupply, the unit will resume from its condition at the point of failure.
- If the failure causes the product to deviate from its desired temperature control limits, products alarms will be activated.
- **Probe Failure** - In general this will not stop the unit from running. However, depending of the nature of the fault the operation of the unit may not be correct and the chill cycle may need to be restarted.
- Failure/Disconnection or severing of a Probe will show as a **PF** symbol in display 24.
- **Overtemperature**
- **Fans** - if the fans overheat, the individual fan thermal overload will cut out the motor to prevent accidental damage.
- **Heaters** - should the internal temperature exceed a preset value due to heater control failure, the overtemperature probe will cause a shut down of the blast chiller.
- Should this fail to operate, a safety stat will terminate all electrical supply.

### 3.9 TEST OUTPUTS

- 3.9.1 **Test Outputs** - This mode allows the installer or service engineer to activate any of the relays for commissioning or testing.
  - Ensure that the display is off. Three bars will be displayed in 17.
  - Press and hold the increment, Decrement and Function buttons together  $\nabla \Delta \text{P}$  and then press the On/Off button  $\text{1/0}$ . Display will show 'tEst'.
  - Display 25 shows the currently selected relay output and display 24 shows the state of that relay (On or Off). Select the required relay by pressing the Function button  $\text{P}$ . Switch the relay on or off by pressing the Increment or Decrement buttons, respectively  $\nabla \Delta$
  - There are seven relays, five on the Tuscan and two on the auxiliary relay board. These are allocated as follows:

| No: | Description:   | Neon: |
|-----|----------------|-------|
| 1   | Compressor 1   | 1     |
| 2   | High Speed Fan | 3     |
| 3   | Low Speed Fan  | 4     |
| 4   | Defrost        | 5     |
| 5   | Alarm          | 7     |
| 6   | Compressor 2   | 2     |
| 7   | Heat           | 6     |

### 3.10 PARAMETER SETTING

Within the control system there are approximately thirty set parameters, shown on the following page.

- To check or modify the parameters.
- Ensure that the display is off. Three bars will be displayed in 17.

Hold down the Increment/Decrement buttons  $\nabla/\Delta$  and simultaneously press the On/Off button  $\text{1/0}$ . The time display will show 'SET'. The parameters are numbered 0 to 30. The parameter number is shown in display 25 and the value of that parameter is shown in display 24.

Use the Increment and Decrement buttons  $\nabla/\Delta$  to adjust the displayed parameter and use the Function button  $\text{C}$  to select the next parameter number.

- Pressing the Program button  $\text{P}$  writes the parameter to the non-volatile memory and returns to standby mode.

- If necessary to reset all the parameters to their factory set default values, press hold the start/stop button  $\text{7/0}$  and then press the Program button  $\text{P}$  and the Alarm button  $\text{bell}$  simultaneously. The Program LED will flash and the controller will revert to standby mode.

Note! the above procedure will erase any programmes that have been previously entered.

#### 3.10.1 Dip Switch Selection

- Situated on the Tuscan Board is a series of Dip Switches.
- For chilling purposes, only switch 1 should be in the On position.

#### 3.10.2 Software Parameters

| No. | Parameter                  |        | Range     | Set | I/D          |
|-----|----------------------------|--------|-----------|-----|--------------|
| 0   | Differential Chill         | °C     | 0 - 10    | 2   | DIFFCHIL     |
| 1   | Differential Freeze        | °C     | 0 - 10    | 3   | DIFFFREEZE   |
| 2   | Differential Hold          | °C     | 0 - 10    | 2   | DIFFHOLD     |
| 3   | Thaw Band                  | °C     | 0 - 10    | 4   | DIFFTHAW     |
| 4   | Thaw Pulse                 | Secs   | 0 - 120   | 30  | THAWPULSE    |
| 5   | Defrost Type               | E/G    | 1/0       | 1   | ELEC         |
| 6   | Defrost Time               | Mins   | 0 - 30    | 15  | DEFTIME      |
| 7   | Defrost Frequency          | Per 24 | 0 - 24    | 4   | DEFFREQ      |
| 8   | Defrost Term. Temp.        | °C     | 0 - 50    | 30  | DEFTTEMP     |
| 9   | Drain Time                 | Mins   | 0 - 10    | 2   | DRAINTIME    |
| 10  | Fan Delay Time             | Mins   | 0 - 10    | 5   | FANDELTIME   |
| 11  | Fan Delay Temp.            | °C     | -10 - 10  | -5  | FANDELTEMP   |
| 12  | Recovery Time              | Mins   | 0 - 60    | 30  | RECTIME      |
| 13  | Compressor Rest Time       | Mins   | 0 - 10    | 0   | COMPRESTTIME |
| 14  | Probe Failure              | On/Off | 0 - 2     | 2*  | PROBEFAIL    |
| 15  | Manual Program Extension   | Mins   | 10 - 30   | 10  | MANTIME      |
| 16  | Surface Protection - Timed | %      | 10 - 40   | 30  | SURPROTTIME  |
| 17  | Surface Protection - Chill | °C     | 0 - 15    | 5   | SURPROTPROB  |
| 18  | Surface Protection - Thaw  | °C     | 0 - 25    | 10  | SURPROTTHAW  |
| 19  | Uncontrolled Mode - Chill  | °C     | 0 - 25    | -15 | UNCONCHILL   |
| 20  | Uncontrolled Mode - Freeze | °C     | 0 - 40    | -35 | UCONFREEZE   |
| 21  | Uncontrolled Mode - Thaw   | °C     | 0 - 25    | 15  | UCONTHAW     |
| 22  | Product Alarm Max Chill    | °C     | 3 - 8     | 5   | MAXCHILL     |
| 23  | Product Alarm Min Chill    | °C     | -3 - 2    | -2  | MINCHILL     |
| 24  | Product Alarm Max Freeze   | °C     | -15 - -5  | -10 | MAXFREEZE    |
| 25  | Product Alarm Min Freeze   | °C     | -35 - -15 | -35 | MINFREEZE    |
| 26  | Product Alarm Max Thaw     | °C     | 3 - 8     | 5   | MAXTHAW      |
| 27  | Product Alarm Min Thaw     | °C     | -3 - -2   | -2  | MINTHAW      |
| 28  | Overtemp Alarm Max         | °C     | 50 - 120  | 80  | OVETEMPMAX   |
| 29  | Alarm Delay Period         | Mins   | 0 - 30    | 10  | ALARMDELAY   |
| 30  | Air Filter Time Constant   | Mins   | 0 - 120   | 90  | FILCONST     |

- \* 0 = Off
- 1 = On
- 2 = Off if Chill/Thaw, On if Freeze

### 3.11 INSTALLATION INSTRUCTIONS

**Coldroom / Evaporator Module** - The coldroom is a standard Foster product. The following Notes and Diagrams are guidelines for room erection.

**NOTE:** Prior to securing, the evaporator module must be supported when the fan door is opened as it will overbalance and fall forward.

- 3.11.1 When installing door jamb, thread the door switch lead through the evaporator module.
- **Fit Control Panel** - The control panel is fitted through obround slots. This is to allow future removal of the door if required.
  - The control panel is designed to be approx. 40mm higher than the roof of the coldroom with cables entering the rear of the panel.
  - The evaporator modules are supplied with 1/2" liquid line and 1 1/8" outlet.
- 3.11.2 **Bumper Bars** - Standard 1.2m x 1.2m rooms will be pre-drilled and rivnuted ready for the bumper bars. On larger rooms bumper bars will be fitted on site. These will require M5 rivnuts (rivnut tool required) or Self tapping screws.
- 3.11.3 **Door Switch Wiring**
- The fan door operates a plunger style switch. It is wired using contacts 1 and 3.
  - The coldroom door switch is a magnetic reed switch. It is a double pole device, with two switches wired in parallel as added security.
  - The door switches must be wired in series.

### 3.12 INSTALLATION INSTRUCTION DIAGRAMS

3.12.1

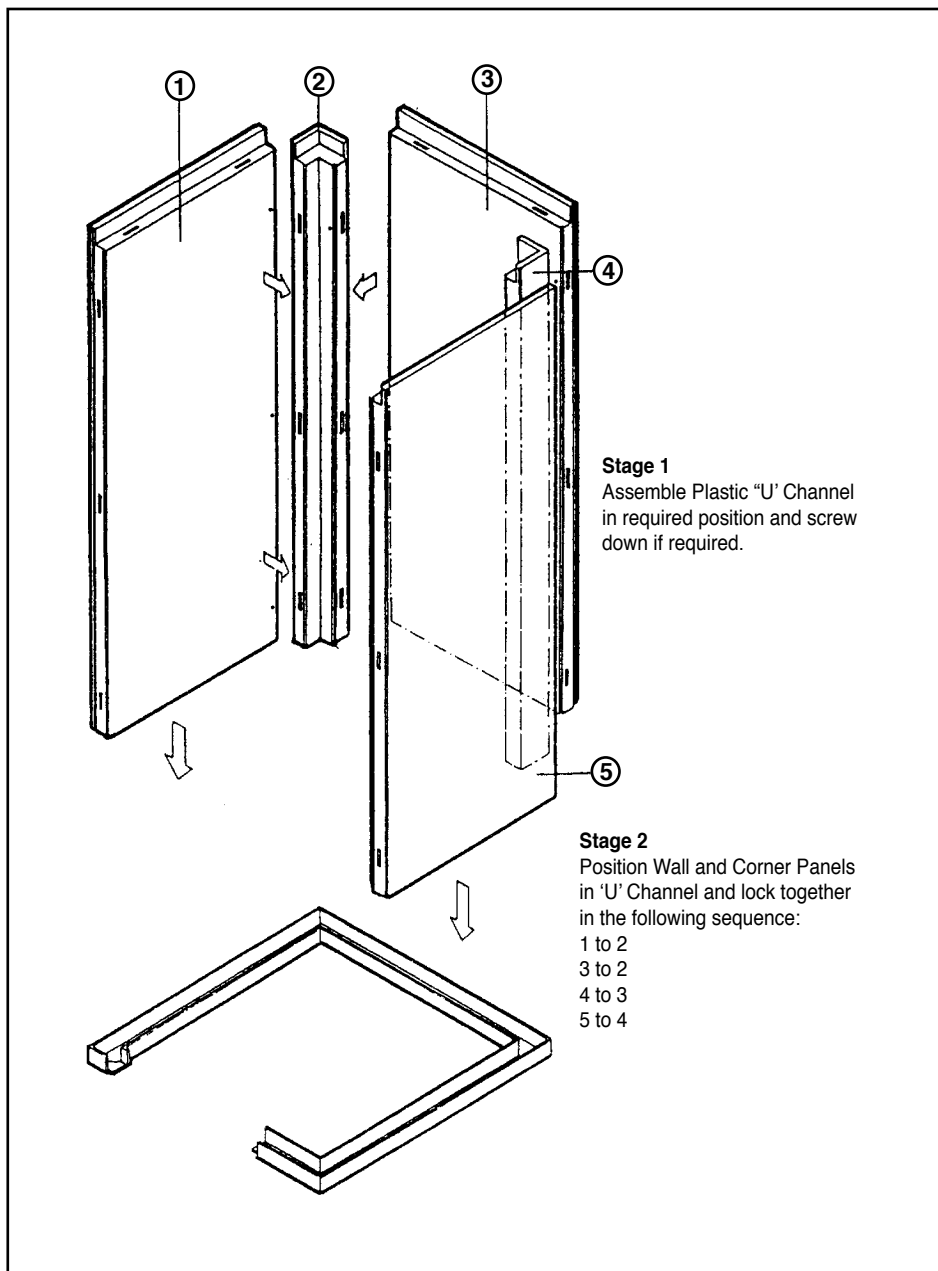

**Stage 4**  
Lock Roof Panels 6 & 7 together.  
Lower assembled Roof panels into position.  
(do not lock to roof panels at this stage)

**Stage 5**  
Lock Door Jamb Unit in position.  
Note - Panels 8, 9, 10 & 11 are supplied assembled.  
Open Fan Assembly Door to lock panel 11 to 5 and to complete fixing of Evaporator Unit to front wall.  
Lock Ceiling Panels to Wall panels

**Stage 3**  
Fit Evaporator Unit in position using fixing screws to the back wall panel (unscrew and swing open Fan Assembly Door for access to fixing holes -  
**Beware unit may overbalance with door open.**  
Note: -  
Adjustable feet on unit legs for height adjustment

**Stage 6**  
Fit Door onto Door Hinges

**Stage 7**  
Remove Access Panel from Control Unit (2 screws)  
N.B. Lower Panel hinges down.  
Fit Control Unit into position with 5 fixing screws in rear face

13.12.4

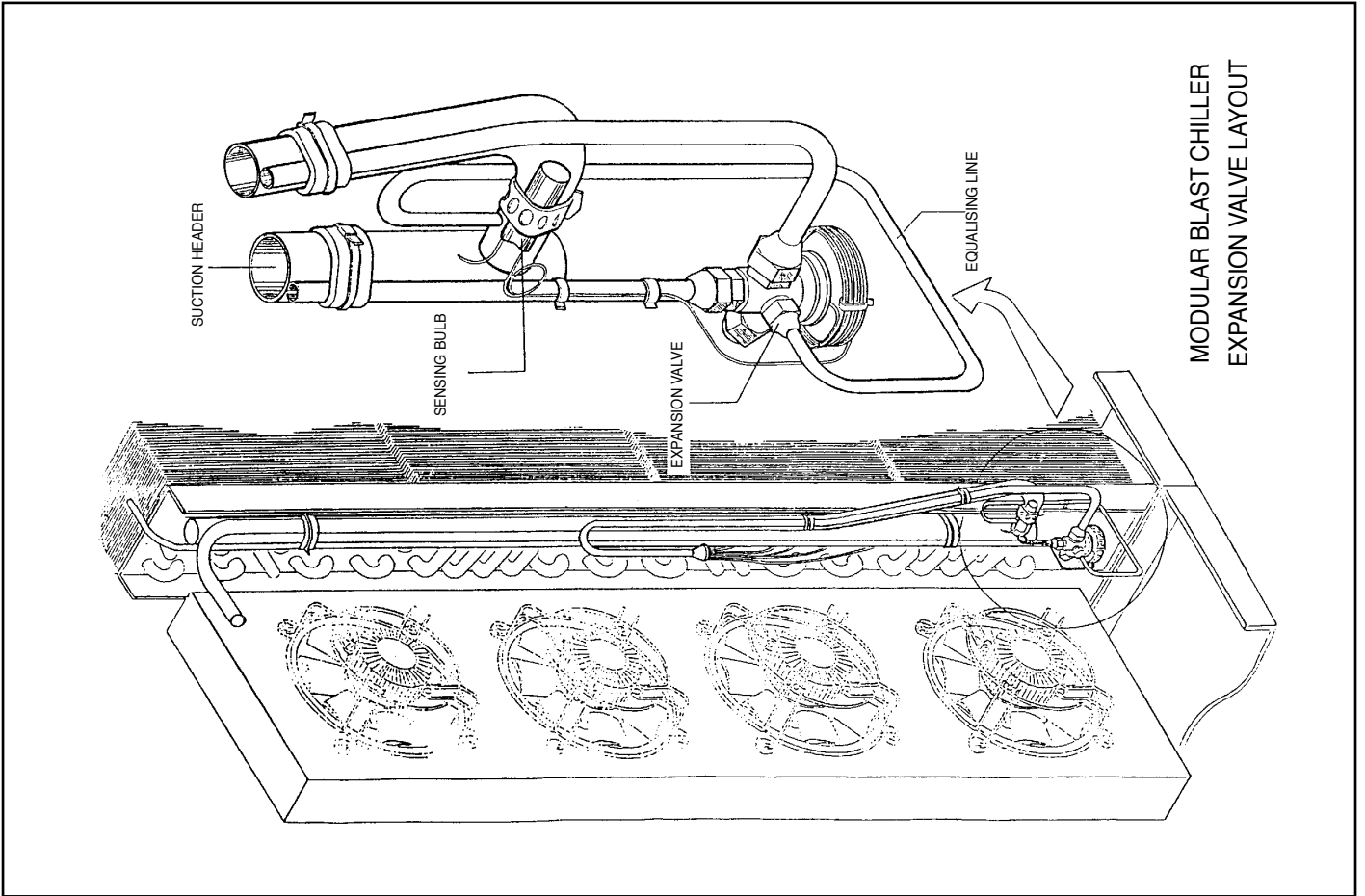

13.12.5

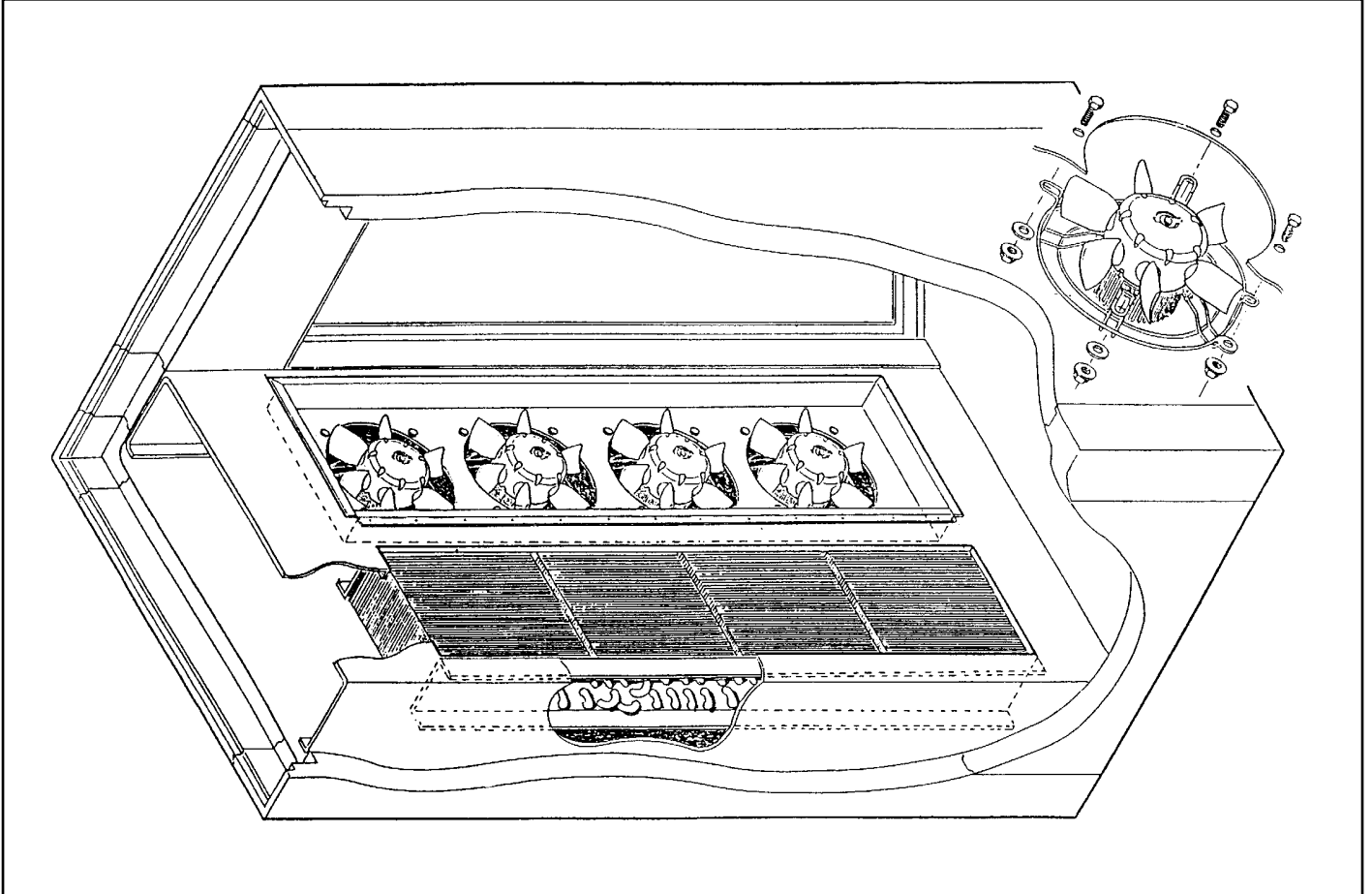

### 3.13 PROBE POSITIONS

