

Prep Top



CONTENT	PAGE	ARTICLE
INTRODUCTION	1	Product description and features
OPERATIONAL DATA	2	Technical specifications and performance



Service Manual



PREP TOP CABINET

CONTENT	PAGE	INTRODUCTION																																																
Introduction	1	<p>Prep Top is a table top storage / display cabinet suitable for storing ingredients used in sandwich or pizza preparation. There are 11 models covering 6 different lengths and 2 different widths. They are available without a glass surround or with either square or curved glass styling. The cabinets are designed to operate in 32°C ambient conditions (ISO Class 4) and maintain product at +3 / +5 °C</p>																																																
Technical Data	2																																																	
Access	3																																																	
Controller and Operation	3																																																	
Controller Parameters	4																																																	
Controller Inputs / Outputs	5																																																	
Electrical Connections	5																																																	
Controller Fault Finding	5 & 6																																																	
Routine Maintenance	6																																																	
Wiring Diagrams	7																																																	
		<p>The models are :</p> <table style="width: 100%; border-collapse: collapse;"> <thead> <tr> <th style="text-align: left;">32cm depth:</th> <th></th> <th></th> </tr> <tr> <th style="text-align: left;">Length (m)</th> <th></th> <th style="text-align: left;">Model</th> </tr> </thead> <tbody> <tr> <td style="text-align: center;">1.4</td> <td></td> <td>PT 142 H</td> </tr> <tr> <td style="text-align: center;">1.6</td> <td></td> <td>PT 162 H</td> </tr> <tr> <td style="text-align: center;">1.8</td> <td></td> <td>PT 182 H</td> </tr> <tr> <td style="text-align: center;">2.0</td> <td></td> <td>PT 202 H</td> </tr> <tr> <td style="text-align: center;">2.1</td> <td></td> <td>PT 212 H</td> </tr> <tr> <td></td> <td></td> <td></td> </tr> <tr> <th style="text-align: left;">38cm depth:</th> <th></th> <th></th> </tr> <tr> <th style="text-align: left;">Length (m)</th> <th></th> <th style="text-align: left;">Model</th> </tr> <tr> <td style="text-align: center;">1.2</td> <td></td> <td>PT 128 H</td> </tr> <tr> <td style="text-align: center;">1.4</td> <td></td> <td>PT 148 H</td> </tr> <tr> <td style="text-align: center;">1.6</td> <td></td> <td>PT 168 H</td> </tr> <tr> <td style="text-align: center;">1.8</td> <td></td> <td>PT 188 H</td> </tr> <tr> <td style="text-align: center;">2.0</td> <td></td> <td>PT 208 H</td> </tr> <tr> <td style="text-align: center;">2.1</td> <td></td> <td>PT 218 H</td> </tr> </tbody> </table>	32cm depth:			Length (m)		Model	1.4		PT 142 H	1.6		PT 162 H	1.8		PT 182 H	2.0		PT 202 H	2.1		PT 212 H				38cm depth:			Length (m)		Model	1.2		PT 128 H	1.4		PT 148 H	1.6		PT 168 H	1.8		PT 188 H	2.0		PT 208 H	2.1		PT 218 H
32cm depth:																																																		
Length (m)		Model																																																
1.4		PT 142 H																																																
1.6		PT 162 H																																																
1.8		PT 182 H																																																
2.0		PT 202 H																																																
2.1		PT 212 H																																																
38cm depth:																																																		
Length (m)		Model																																																
1.2		PT 128 H																																																
1.4		PT 148 H																																																
1.6		PT 168 H																																																
1.8		PT 188 H																																																
2.0		PT 208 H																																																
2.1		PT 218 H																																																

PREP TOP TECHNICAL DATA

Model	Refrigerant	Quantity Gms	Evap Temp	Capacity Watts	Heat Rejected Amps	Start Amps	Run Amps	Power Abs	Capillary
PT 142H	R 134a	170	-15°C	165	385	3.8	1.5	220 W	2.9m x 0.91mm
PT 162H	R 134a	190	-15°C	165	385	3.8	1.5	220 W	2.9m x 0.91mm
PT 182H	R 134a	190	-15°C	165	385	3.8	1.5	220 W	2.9m x 0.91mm
PT 202H	R 134a	210	-15°C	165	385	3.8	1.5	220 W	2.9m x 0.91mm
PT 212H	R 134a	210	-15°C	165	385	3.8	1.5	220 W	2.9m x 0.91mm
PT 128H	R 134a	150	-15°C	140	290	3.2	1.2	150 W	2.9m x 0.91mm
PT 148H	R 134a	170	-15°C	165	385	3.5	1.5	200 W	2.9m x 0.91mm
PT 168H	R 134a	190	-15°C	165	385	3.5	1.5	200 W	2.9m x 0.91mm
PT 188H	R 134a	190	-15°C	165	385	3.5	1.5	200 W	2.9m x 0.91mm
PT 208H	R 134a	210	-15°C	165	385	3.5	1.5	200 W	2.9m x 0.91mm
PT 218H	R 134a	210	-15°C	165	385	3.5	1.5	200 W	2.9m x 0.91mm

ACCESS TO THE UNIT COMPARTMENT

- Glass Panels:** If fitted with glass panels remove the top, front, and left hand side panel.
- Unit Top Cover:** Remove the 2 large screws located at the top rear of the unit cover. Gently “pull forward” releasing it from 2 metal clips fitted to the top of the main cabinet shell. Take care when lifting the cover as the temperature controller and mains on / off switch are located in the front avoiding breaking any wires / connectors.
- Unit Side Panel:** With the top cover removed, this exposes the side panel fixing screws located in the unit compartment.

CONTROLLER AND OPERATION

DESCRIPTION OF THE OPERATING CONTROLS

All the manual controls are grouped together on the relative control panel bearing easy-to-read symbols which facilitate immediate operation. These controls are shown schematically in the drawing below:

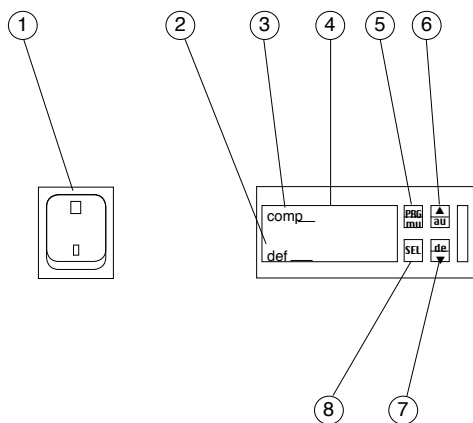

- 1 - On/off switch (when switched on the green button lights up)
- 2 - Defrosting light
- 3 - Compressor operation light
- 4 - Digital thermostat
- 5 - Programming key (not accessible to the user)
- 6 & 7 - Temperature modification keys
- 8 - Selection key

DISPLAY

During normal working conditions, the display shows the value measured by the regulation probe. In case of active alarm, the relative code blinks alternatively with the alarm code.

SET-POINT

- Press the SEL button for one second to display the Set-Point value;
- After two seconds, the set value blinks;
- Press ▲ or ▼ to increase or decrease the value;
- Press the SEL button to confirm the new value.

DEFROSTING

The internal compartment must be defrosted periodically by following the sequence hereunder:

- disconnect the appliance from the mains;
- wait until the traces of ice inside the refrigerating compartment have melted;
- dry the refrigerating compartment with a soft cloth;
- switch the on/off switch to “on”.

INDICATIONS ON THE DISPLAY

- | | |
|------|--|
| COMP | 1 LED to indicate compressor ON |
| | 2 LEDs to indicate Continuous Cycle ON |
| DEF | Defrost ON |

CONTROLLER PARAMETERS

PARAMETERS

The parameters have been divided into two sections:

First Section: Frequent parameters (type F in the table):
no password is required to enter:

- Press the PRG button for more than five seconds.
- The first modifiable parameter code is displayed.

Second Section: Configuration parameters (type C in the table), a password is required to enter.

- Press PRG and SEL simultaneously for more than five seconds;
- 00 is displayed;
- Press ▲ or ▼ until 22 is displayed (password);
- Press SEL to confirm;
- The first modifiable parameter code is displayed.

To modify the parameters see "Parameters Modification" below.

PARAMETERS MODIFICATION

- Press ▲ or ▼ to show the code of the parameter that has to be changed;
- Press SEL to display the selected parameter value;
- Press ▲ or ▼ to increase or decrease the value;
- Press SEL to confirm temporarily the new value and display its code;
- Repeat the procedure from the beginning "press ▲ or ▼ to show..."

To exit modifying the parameters with the new values:

- Press PRG to confirm the new values and exit the parameters modification procedure.

For timing parameters only:

- Switch off and switch on the controller in order to make them immediately effective (without waiting for the following cycle).

To exit without modifying any parameter:

- Do not press any button for at least 60 seconds (TIME OUT).

DUTY SETTING (PARAMETERS A6 and c4)

In case of regulation probe failure (E0 blinks), the ON routine of the compressor is defined by c4:

- If c4 has a value from 1 to 99, the compressor will go on working for a set c4 time (minutes). The OFF routine of the compressor will last for fifteen minutes;
- If c4=0 the compressor will always be ON;
- If c4=100 the compressor will always be OFF. The ON routine of the compressor is defined by A6:
- If A6 has a value from 1 to 99, the compressor will go on working for a set A6 time (minutes). The OFF routine of the compressor will last fifteen minutes;
- If A6=0 the compressor will always be ON;
- If A6=100 the compressor will always be OFF.

LIST OF PARAMETERS

	Parameter	Type	Min	Max	U.M.	Def
PA	PASSWORD	C	00	+199	-	22
/	PROBE PARAMETERS					
/C	Calibration	F	-20	+20	°C/°F	0.0
/2	Reading stability	C	1	15	-	4
/3	Reading speed	C	1	15	-	8
/4	Virtual probe	C	0	100	-	0
/5	°C/°F (0=°C, 1=°F)	C	0	1	flag	0
/6	Decimal point (0=yes, 1=no)	C	0	1	flag	1
r	REGULATOR PARAMETERS					
rd	Regulator differential	F	0.1	+19.9	°C/°F	2
r1	Minimum allowable set	C	-50	r2	°C/°F	0
r2	Maximum allowable set	C	r1	+199	°C/°F	15
r3	Direct (0) / Reverse (1)	C	0	1	-	0
r4	Automatic variation of the Set-Point when the curtain-switch is closed (A4 or A5=7)	C	0	+20	°C/°F	3.0
r5	Enabling monitoring minimum and maximum temperature (0=no, 1=yes)	C	0	1	flag	0
rt	Effective temperature monitoring	F	0	199	hours	-
rH	Maximum temperature monitored on the rt interval	F	-	-	°C/°F	-
rL	Minimum temperature monitored on the rt interval	F	-	-	°C/°F	-
c	COMPRESSOR PARAMETERS					
c0	Delay compressor insertion after controller reset	C	0	15	min	2
c1	Minimum time between two insertions	C	0	15	min	2
c2	Minimum OFF routine	C	0	15	min	3
c3	Minimum ON routine	C	0	15	min	0
c4	Safety relay (0=OFF, 100=ON). See duty setting	C	0	100	min	100
cc	Continuous cycle duration	C	0	15	hours	0
c6	Alarm delay after continuous cycle	C	0	15	hours	0
d	DEFROST PARAMETERS (only in S functioning)					
dl	Time interval between two defrost cycles	F	0	199	hours	0
dP	Defrost duration	F	1	199	min	1
d4	Defrost after controller Switch-On (0=no, 1=yes)	C	0	1	flag	0
d5	Delay defrost after controller Switch-On or from digital input (A4 or A5=4)	C	0	199	min	0
d6	Block of display during defrost (0=no, 1=yes)	C	0	1	flag	0
dd	Dripping time	F	0	15	min	0
d8	Alarm delay after defrost and/or when door is open	F	0	15	hours	0
d9	Priority of the defrost over anticogging (0=no, 1=yes)	C	0	1	flag	0
d/	Defrost probe reading	F	-	-	°C/°F	-
dC	Time selection (0=hours/min. 1=min/s)	C	0	1	flag	0
A	ALARM PARAMETERS					
A0	Alarms delta	C	0.1	+20	°C/°F	1
AL	Low temperature alarm (with respect to Set-Point) AL=0 alarm inhibited	F	0	+199	°C/°F	199
AH	High temperature alarm (with respect to Set-Point) AH=0 alarm inhibited	F	0	+199	°C/°F	199
Ad	Temperature alarm delay	C	0	199	min	120
A4	Configuration of the digital input No.1	C	0	7	-	3
A5	Configuration of the digital input No.2	C	0	7	-	0
A6	Duty setting in case of external alarm (0=OFF, 1=ON)	C	0	100	min	0
A7	External alarm delay (A4 or A5=2)	C	0	199	min	0
H	OTHER SELECTIONS					
H0	Serial address	C	0	199	-	0
H1	Mode (0=T, 1=T+D)	C	0	1	flag	0
H2	0=buttons disabled 2=IR and buttons disabled 3=IR disabled	C	0	3	flag	1
H3	Password for Infrared	C	00	199	-	00
H4	1=buzzer or alarm relay disables	C	0	1	flag	0

NOTE: Concerning the parameters with grey background: it is recommended to check, before installing, if the factory value is suitable for the required use.

INPUTS

Air Temperature Probe - Senses internal storage chamber temperature. Negative temperature / resistance coefficient thermistor probe.

Transformer - Mains low voltage from a transformer to supply the temperature controller.

OUTPUTS

Compressor - Relay output switching single phase mains supply to the compressor.

CONTROLLER BOARD ELECTRICAL CONNECTIONS

Terminal Numbers	Output	Terminal Numbers	Output
1	Compressor Supply.	5	Transformer.
2	Illuminated on/off switch.	6	Air Probe.
4	Transformer.	7	Air Probe.

CONTROLLER ALARMS AND FAULT FINDING

ALARMS AND SIGNALS - Blinked functioning LED:

- If a led blinks it means that the corresponding function is delayed by a timed routine (see parameters table), by another procedure or inhibited by the digital input.

EO BLINKS - Faulty regulation probe:

- Used probe is not compatible with the control;
- The probe cable is interrupted or short circuited;
- Faulty sensor: take out the probe from the control and verify the resistance (NTC: $0^{\circ}\text{C}=27\text{K}\Omega$).

The Alarm disappears as soon as the temperature rises and ranges within the selected lower limit.

EA, EB, EE - Data acquisition failure; controller RESET: Set again the default parameters value:

- Switch off the control;
- Press the PRG button while switching on the control; (*)
- '-c-' is displayed;
- After a few seconds the RESET phase begins and it is possible to change the parameters; (*).
- IF EE persists, press the  button until the error indication disappears.

(*) Re-setting the default values causes the loss of the modifications relative to the working parameters.

The causes of malfunctioning are often due to problems that can be easily resolved.

Check the following points, according to the problem encountered, and carry out the corresponding recommended operation, before calling the service centre:

1. The refrigerating unit does not start

- switching off using the on/off switch - the appliance starts again after 3 minutes/operating on compressor delay
- no power supply - check plug, sockets, fuses and power
- other causes - contact the service centre

2. The refrigerating unit operates continuously but does not cool sufficiently

- room too hot - ventilate the room or move any heat sources away from refrigerating unit
- the condenser is dirty - clean the condenser
- insufficient quantity of refrigerant gas - contact the service centre
- condenser fan stopped - contact the service centre

3. The refrigerating unit does not stop

- broken sensor - contact the service centre
- broken thermostat - contact the service centre

4. Noisy appliance

- persistent vibrations - check that the appliance does not touch other objects, either inside or outside.

5. Thermostat failure signal

- e1 = temperature sensor defective - contact the service centre

If it is impossible to resolve the malfunctioning or trouble using the above check list, only then contact the service centre specifying:

- the nature of the fault;
- the serial number, which can be found on the label attached to the rear of the appliance.

MAINTENANCE

INSTRUCTIONS FOR ROUTINE MAINTENANCE

The instructions given in the following paragraph are for the user and consequently for **UNSKILLED PERSONNEL**.

CLEANING THE EQUIPMENT

Before starting the appliance and during periodic maintenance work, wash the interior of the refrigerating compartment and the accessories with luke warm water and a neutral detergent, avoiding the use of abrasive substances or chlorine compounds on the walls.

Also avoid using tools which may scratch the metal parts.
Rinse thoroughly with clean water and dry carefully.

Soften any encrustation with soap and water and delicately remove using a plastic spatula.

PERIODS OF INACTIVITY

If the appliance is to be left inactive for long periods, proceed as follows:

- unplug the appliance after having turned the on/off switch to the OFF position.
- empty the refrigerating compartment and clean thoroughly (see cleaning).

INSTRUCTIONS FOR SPECIAL MAINTENANCE

The instructions given in the following paragraph are for **SKILLED PERSONNEL**.

PERIODIC OPERATIONS

- Periodically clean the condenser using suitable tools (vacuum cleaner or soft brushes).
- Check that the electrical connections are not loose.
- Check that the thermostat and the sensors are in proper working order.

We recommend you use original spare parts.

Failure to observe this rule relieves the manufacturer of any responsibility concerning the correct operation of the appliance.

Note!

All service work must be carried out by a competent engineer and the cabinet must be switched off at the mains supply.

- Wiring diagrams Refrigerating Display Cases
- Schema elettrico Vitrine Refrigerate
- Schältplane Kühlvitrine
- Schémas electr. Vitrines Refrigerées

Key:

- St = Temperature sensor
- Sl = Line pilot light
- C = Compressor
- V = Condenser fan
- Te = Thermostat
- Pr = Thermal protection C
- Ig = On/Off switch
- Tr = Transformer 220/12V

220 - 230 V - 50 Hz

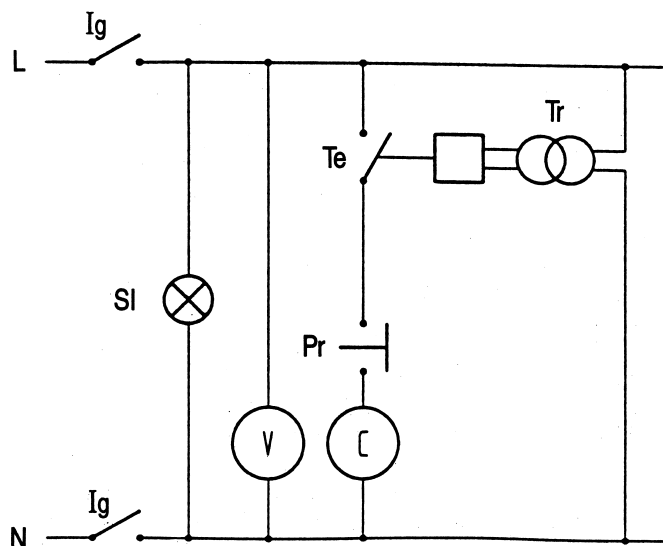
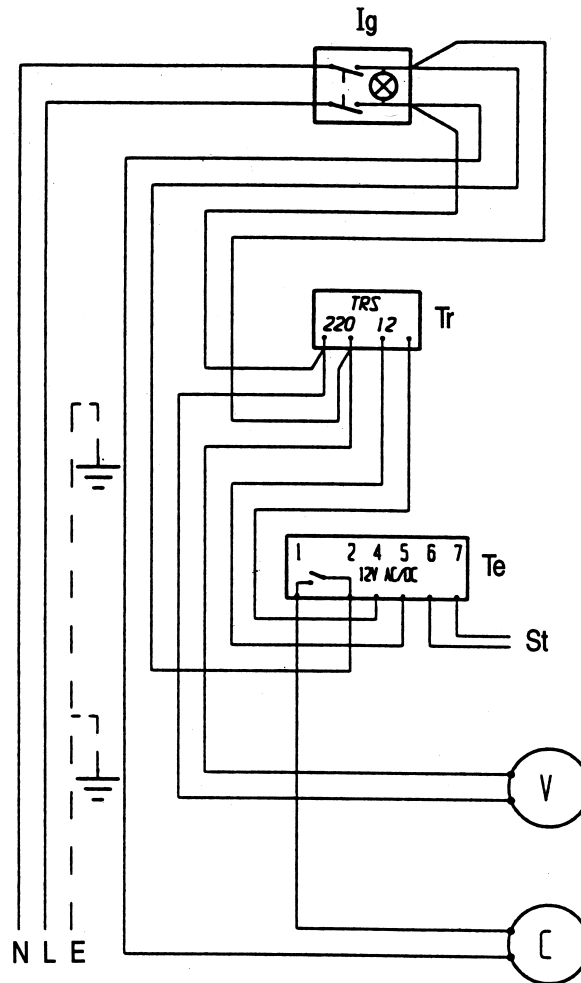

Foster European Operations

France

Foster Refrigerator France SA
Tel: 33 (01) 34 302222. Fax: 33 (01) 30 376874.

Germany

Foster Refrigerator GmbH
Tel: 49 (202) 64780. Fax: 49 (202) 643044.

Austria

Foster Refrigerator Austria
Tel: 43 (1) 815 1511. Fax: 43 (1) 813 29 36.

Spain/Portugal

Foster Refrigerator (Iberica)
Tel: 34 (43) 463222. Fax: 34 (43) 463246.

Holland

Hobart Foster Holland BV
Tel: 31 (348) 433 331. Fax: 31 (348) 430 117.

Belgium

Hobart Foster Belgium NV
Tel: 32 (16) 606040. Fax: 32 (16) 605988.

Denmark

Hobart Foster Danmark A/S
Tel: 45 (98) 141199. Fax: 45 (98) 141703.

Norway

Hobart Foster Norge A/S
Tel: 47 (67) 533878. Fax: 47 (67) 536742.

Sweden

Hobart Foster Sverige AB
Tel: 46 (86) 280030. Fax: 46 (86) 280024.

PMI FEG Offices

Asia/Pacific

PMI Food Equipment Group (Hong Kong) Ltd
Tel: (852) 3419315. Fax: (852) 3413914.

Middle East

PMI Food Equipment Group (Dubai)
Tel: 971 (4) 497393. Fax: 971 (4) 448232.

Japan

PMI Food Equipment Group (Japan) Inc
Tel: 81 (3) 37443511. Fax: 81 (3) 37444011.

Malaysia

PMI Food Equipment Group (Malaysia) Inc
Tel: 603 780 6779. Fax: 603 781 4535.

Singapore

PMI Food Equipment Group (Singapore) Inc
Tel: 65 665 0487. Fax: 65 665 0487.

IMPORTANT:

To the installer

Installation of these units should be carried out by a competent person and the appropriate codes of practice adhered to, thus ensuring safe installation.

To the user

Do not discard this document: it contains important guidelines on loading, cleaning and maintenance and should be kept for reference.

Foster Refrigerator Group of Companies,

Oldmedow Road, King's Lynn,
Norfolk, PE30 4JU
England

Tel: 01553 691122

Fax: 01553 691447



Service Manual