



GUARANTEEING YOU THE GREENEST REFRIGERATION AVAILABLE



Slimline Range With LF28 Controller



Service Manual



ISO 14001

ISO 9001



Re-Issued Version July 2010

Contents









Manual Information & Health & Safety Notes	1
Environmental Management Policy	2
Disposal Requirements	2
Cabinet Description	3
Controller Operation	4
User Functions	4
Defrost Operation & Alarms	4 to 6
Parameter Setting & Fuzzy Logic	6 to 7
Controller Information Label	7
Parameter Settings	8 to 10
Wiring Diagrams	11 to 12
Troubleshooting & Notes	13 to 15

Service Manual Information

The products and all information in this manual are subject to change without prior notice. We assume by the information given that the person(s) working on these refrigeration units are fully trained and skilled in all aspects of their workings. Also that they will use the appropriate safety equipment and take or meet precautions where required.

The service manual does not cover information on every variation of this unit; neither does it cover the installation or every possible operating or maintenance instruction for the units.

Health & Safety Warnings and Information

	Make sure the power supply is turned off before making any electrical repairs.
	To minimise shock and fire hazards, please do not plug or unplug the unit with wet hands.
	During maintenance and cleaning, please unplug the unit where required.
	Care must be taken when handling or working on the unit as sharp edges may cause personal injury, we recommend the wearing of suitable PPE.
	Ensure the correct moving and lifting procedures are used when relocating a unit.
	Do NOT use abrasive cleaning products, only those that are recommended. Never scour any parts of the refrigerator. Scouring pads or chemicals may cause damage by scratching or dulling polished surface finishes.
	Failure to keep the condenser clean may cause premature failure of the motor/compressor which will NOT be covered under warranty policy.
	Do NOT touch the cold surfaces in the freezer compartment. Particularly when hands are damp or wet, skin may adhere to these extremely cold surfaces and cause frostbite.
	Please ensure the appropriate use of safety aids or Personnel Protective Equipment (PPE) are used for you own safety.

Environmental Management Policy for Service Manuals and Duets.

Product Support and Installation Contractors

Foster Refrigerator recognises that its activities, products and services can have an adverse impact upon the environment.

The organisation is committed to implementing systems and controls to manage, reduce and eliminate its adverse environmental impacts wherever possible, and has formulated an Environmental Policy outlining our core aims. A copy of the Environmental Policy is available to all contractors and suppliers upon request.

The organisation is committed to working with suppliers and contractors where their activities have the potential to impact upon the environment. To achieve the aims stated in the Environmental Policy we require that all suppliers and contractors operate in compliance with the law and are committed to best practice in environmental management.

Product Support and Installation contractors are required to:

1. Ensure that wherever possible waste is removed from the client's site, where arrangements are in place all waste should be returned to Foster Refrigerator's premises. In certain circumstances waste may be disposed of on the client's site; if permission is given, if the client has arrangements in place for the type of waste.
2. If arranging for the disposal of your waste, handle, store and dispose of it in such a way as to prevent its escape into the environment, harm to human health, and to ensure the compliance with the environmental law. Guidance is available from the Environment Agency on how to comply with the waste management 'duty of care'.
3. The following waste must be stored of separately from other wastes, as they are hazardous to the environment: refrigerants, polyurethane foam, and oils.
4. When arranging for disposal of waste, ensure a waste transfer note or consignment note is completed as appropriate. Ensure that all waste is correctly described on the waste note and include the appropriate six-digit code from the European Waste Catalogue. Your waste contractor or Foster can provide further information if necessary.
5. Ensure that all waste is removed by a registered waste carrier, a carrier in possession of a waste management licence, or a carrier holding an appropriate exemption. Ensure the person receiving the waste at its ultimate destination is in receipt of a waste management licence or valid exemption.
6. Handle and store refrigerants in such a way as to prevent their emission to atmosphere, and ensure they are disposed of safely and in accordance with environmental law.
7. Make arrangements to ensure all staff who handle refrigerants do so at a level of competence consistent with the City Guilds 2078 Handling Refrigerants qualification or equivalent qualification.
8. Ensure all liquid substances are securely stored to prevent leaks and spill, and are **not** disposed of to storm drains, foul drain, or surface water to soil.

Disposal Requirements

If not disposed of properly all refrigerators have components that can be harmful to the environment. All old refrigerators must be disposed of by appropriately registered and licensed waste contractors, and in accordance with national laws and regulations.

Slimline Cabinet Description

The cabinets are manufactured as a one piece foamed shell.

The condensing unit is located on the base of the cabinet.

The cabinets conform to ISO Climate Class 5. (40⁰c with 40% RH)

Temperature is controlled by a microprocessor control with digital temperature display.

The refrigeration system is integral with an air-cooled condensing unit with the refrigerant distribution into the evaporator controlled by capillary.

The cooled air is circulated through the evaporator, via the fan into the storage area.

A plastic vaporiser tray with the hot gas line inserted into it is provided for condensate vaporisation.

The FSL400 H, FSL600H and FSL 800 H have a temperature range of +1⁰c to +4⁰c with a timed off cycle defrost.

The FSL400 L, FSL600L and FSL 800 L have a temperature range of -18⁰c to -21⁰c with electric defrost set at 4 times per 24 hours.

The solid doors are fitted with pivot hinges, recessed door handle and magnetic door gasket.

The glass doors are fitted with pivot hinges, surface mounted door handle and magnetic door gasket.

On glass door models the interior light, incorporating the on/off switch, is fitted to the top of the storage area at the front.

All models are fitted with lockable swivel castors to the front and swivel castors to the rear.

Nomenclature based on –

FSL = Foster Slim Line. 400/ 800 = Net Capacity (litres). H = High Temperature. L = Low Temperature.

G = Glass Door

Model Ref.		FSL 400H	FSL 400L	FSL 800H	FSL 800L
Temperature range		+1 ⁰ c to +4 ⁰ c	-18 ⁰ c to -21 ⁰ c	+1 ⁰ c to +4 ⁰ c	-18 ⁰ c to -21 ⁰ c
Refrigerant		R134a	R404a	R134a	R404a
Compressor Part Number		00-555664	00-555680	00-555667	00-555681
Capillary		3m x 042	2.5m 042	3m x 054	3m x 054
Defrost Type		Timed Off Cycle	Electric	Timed Off Cycle	Electric
Heat Output		680	1104	1300	1488
Extraction Rate		400	520	780	730
Voltage		220-1-50	220-1-50	220-1-50	220-1-50
Power Consumption	Watts	280	584	520	758
	Amps	2.1	3.8	3.6	4.1
Fuse Rating Amps		13	13	13	13

Operation Guidelines for Foster controller part number LF 28B2SE-B (00-555920)



Controller with the LCD 16 Display (00-555740) fitted as from May 2007 to November 2007
Controller display LCD5s (00-555992) fitted as from November 2007

Operation Guidelines

Initial Start Up.

Start Up & self Test:



The indication is only displayed during the first three seconds following the mains electrical power being applied to the unit. During this period the controller performs a self-check.

Once the self-check has been completed  will be displayed.

Press and hold  for three seconds. The unit will start and the air temperature will be displayed.

Check temperature set point.

Important to note that the ability to increase and decrease the set point is not a function available to the user as the set point is fixed. To make adjustments to the set point it is necessary to access the parameter and alter SPL and SPH accordingly.

Check set point by pressing the button



To increase set point press  +  until required temperature is displayed.

To decrease set point press  +  until required temperature is displayed.

Factory Temperature Set Point

Refrigerator +1°C to +4°C

Meat 0°C to 2°C.

Freezer -18°C to -21°C.

Exit from set up occurs after 10 seconds if no button is pressed.

Manual Defrost.

To initiate a manual defrost press  and  hold will be displayed release. 

On completion of the defrost  will be displayed until the cabinet temperature is achieved and then it will revert to displaying the normal cabinet temperature.

Set Unit to Standby.

Press  display shows 

This indication is displayed while the unit is not operating but with mains power applied to the unit. This mode may be used for internal cleaning regimes and short periods when the unit is not required.

For extended periods of inactivity the mains supply should be isolated.

Auto Defrost operation.

The defrost frequency is determined by the usage of the machine.

In the economy mode it may not perform a defrost as by monitoring the air temperature, evaporator temperature and door opening factor it may decide that there is insufficient ice build up on the evaporator so defrosting is not required. The parameter DFR (defrost frequency) is set for 3. The cabinet will perform at least 1 defrost per day and with the setting at 3 it has the potential to initiate up to 2 additional defrost in the economy mode.

Should the cabinet experience constant usage the controller will switch automatically to the second parameter settings indicated by the controller LED adjacent to illuminating, which could under circumstances of heavy usage initiate up to 6 defrosts per day.

The second parameter settings preceded by 11 will now be active,

It is important to note that during the first few days of operation the defrosting frequency may be at regular intervals but these will reduce as the controller monitors the operation.

Alarm and Warnings

High temperature alarm

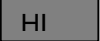
 Will be displayed.

The alarm will sound but can be silenced by pressing any of the buttons, however it will return after the pre-set designated period. The unit returning to normal operating temperature will automatically cancel the alarm.

Possible Causes: Evaporator fan not working. Restricted airflow through airduct. Evaporator iced up. Compressor not working.

Low temperature alarm.

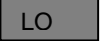
 Will be displayed.

The alarm will sound but can be silenced by pressing any of the buttons and the unit will continue to operate, however it will return after the pre-set designated period. The unit returning to normal operating temperature will automatically cancel the alarm.

Possible Causes: Controller faulty (not switching compressor off). Compressor secondary relay will not de-energise (low temperature models).

Door Open Alarm. (Only applies to cabinets fitted with door switches.)

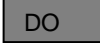
 Will be displayed.

The alarm will sound but can be silenced by pressing .

The display will continue to display the alarm message until cancelled by shutting the door.

If the alarm cannot be cancelled by doing this call your Foster Authorised Service Company.

Possible Causes: Faulty door switch. Door left open for more than 5minutes.

High Pressure Alarm (Only applies to machines fitted with a condenser probe).

 Will be displayed

This alarm relate to the condenser which must be checked and cleaned at regular intervals the frequency being determined by site conditions.

The alarm will sound but can be silenced by pressing any of the buttons and the unit will continue to operate, however it will return after the pre-set designated period. The unit returning to normal operating temperature will automatically cancel the alarm.

Possible Causes: Condenser fan not working. Condenser blocked/ dirty. Condenser obstructed.

Air Temperature Probe Failure.

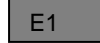
 Will be displayed.

The alarm will sound but can be silenced by pressing any button.

There is no further action that can be taken by the user in this instance. During this period the unit will continue to operate but have a reduced performance.

Action: Replace Probe.

Evaporator Temperature Probe Failure. (Automatic Defrost Cabinets Only)

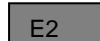
 Will be displayed.

The alarm will sound but can be silenced by pressing any button.

There is no further action that can be taken by the user in this instance. During this period the unit will continue to operate satisfactorily, but this failure will have an effect on the defrost and therefore efficiency if allowed to continue.

Action: Replace Probe.

Information Menu

Pressing and releasing  activates the information menu. From this menu you can display the temperature relating to T1 (air probe), T2 (evaporator probe, if fitted) and T3 (condenser probe, if fitted). The maximum temperature (THI) and the minimum temperature (TLO) the cabinet has achieved since it was last re-set.

The total operating time of the condenser (CND), since it was last cleaned, and the keyboard status (LOC).

The information to be displayed can be selected sequentially by pressing  repeatedly or scrolling through the menu using the  or  buttons.

Once selected press  to display the value

Exit from the info menu by pressing  or is automatic after 6 seconds if no buttons are pressed.

To reset the temperature settings recorded in THI and TLO and the hours counted in CND, access the info menu



press  to display the value plus  simultaneously for resetting to be completed.

To check the LOC status scroll through to LOC, press  to display status – YES to lock keys. – NO to leave keys accessible.



NOTE: with the keys locked it is not possible to turn the unit off or ON or to check the set point

Parameter Setting and Adjustment

It is strongly advised that before adjusting any Service Parameters a thorough understanding of the following instructions should be obtained.

The parameters are accessed by pressing the following keys in succession  +  and keeping them pressed for 5 seconds.

After this period the first parameter 'SCL' will be displayed.



Press button  to pass from one parameter to the next and button  to go back.

Press  to display the value +  or  to change it.

Exit from set up is by pressing  or is automatic if no buttons are pressed for 30 seconds

NOTE:

When receiving a replacement controller the unit will be set with the default settings. Change the settings to those relating to the particular model. After changing parameter 'SCL' from '1' to '2' moving through parameters 'SPL', 'SP', 'FDD', 'IISL' and 'IISP' you may find that '-or' will be displayed. '-or' indicates that the control setting is out of range.

To get the parameter back into range, for example 'SPL', press  to display the value +  continue pressing both buttons until the display shows the temperature required then release both buttons. Use the same procedure to adjust all of the parameters displaying '-or'.

Fuzzy Logic.

These are settings that maintain the temperature of the cabinet in a more energy efficient manner.

It works by controlling the evaporator fan/s, defrost and temperature in low usage times by transferring the operation to a second set of economy parameters.

When the cabinet is first switched On the economy settings control the operation of the temperature and will remain at those settings until the controller, by monitoring the door opening frequency and the air and evaporator temperatures, identifies a higher usage and switches over to the 11SM (2nd parameter set management).

When the economy settings are activated the cabinet temperature is allowed to rise to the setting (SP) set point [1]. This is set to a higher temperature setting to allow the air temperature to rise without having much of an impact on the product temperature.

In addition the fan/s will modulate (cycle for 30 seconds) as set in (FPC) evaporator fan On / Off Ratio.

The parameter is set at 1.

Changing the setting to 0 will have the fan running with the compressor. Set to 1 the fan will run for 30 seconds on and 60 seconds off. Set to 2 the fan will run for 60 seconds on and 60 seconds off and set to 3 the fan will run for 90 seconds on and 60 seconds off.

With FPC set to 1, 2 or 3 the fans will generate less heat into the cabinet therefore reduce the requirement of the condensing system.

NOTE:

Parameter FPC will only function with the parameter FTC set for YES. With FTC set to NO the fan will run all of the time apart from during defrost when it will be off during electric and hot gas defrost but on during a timed off cycle defrost.

Fan Operation.

The evaporator fan/s will run normally when the compressor is running but will commence cycling when the compressor is in the off cycle mode.

The fans will run without the compressor during timed off cycle defrost but will not run during hot gas or electric defrost.

For models that don't have door switches fitted the fuzzy logic will not function as the controller is unable to monitor door opening factors.

Controller Information Label

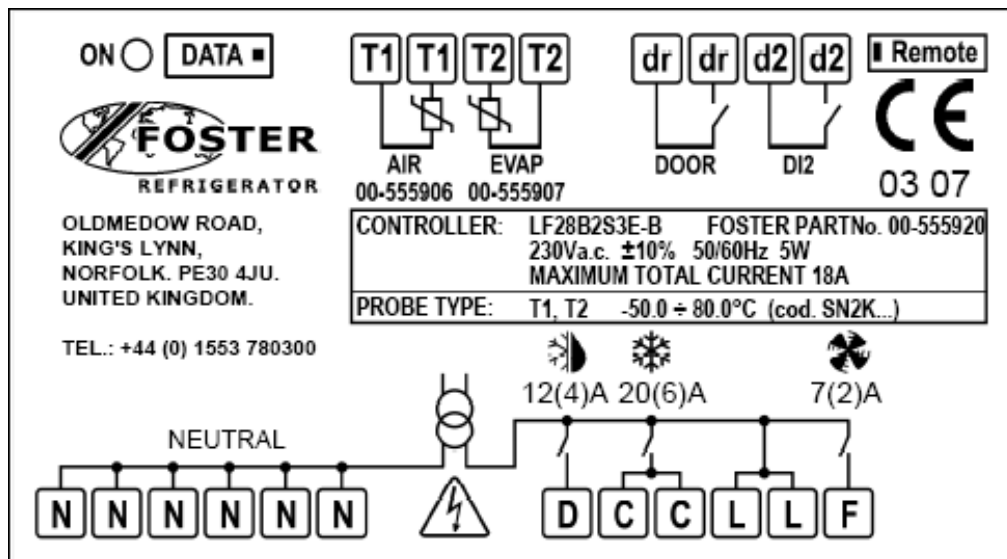

NOTE:

When receiving a replacement controller the unit will be set with the default settings. Change the settings to those relating to the particular model. After changing parameter 'SCL' from '1' to '2' moving through parameters 'SPL', 'SP', 'FDD', 'IISL' and 'IISP' you may find that '-or' will be displayed. '-or' indicates that the control setting is out of range.

To get the parameter back into range, for example 'SPL', press **i•set** to display the value + **▶▶II** continue pressing both buttons until the display shows the temperature required then release both buttons. Use the same procedure to adjust all of the parameters displaying '-or'.

Parameter settings for the FSL400H and FSL 800 H

Mnem.	Definition	Min.	Max	Default	Dim.	H Temp
SCL	Readout scale	1°C; 2°C; °F		2	flag	2
SPL	Minimum set point [I]	-40	SPH	1	°C	1
SPH	Maximum set point [I]	SPL	40	3	°C	3
SP	Set point [I]	SPL	SPH	2	°C	2
HYS	Thermostat hysteresis [I]	0.1	10	3	°K	3
CRT	Minimum compressor rest time	0	30	2	min.	2
CT1	Compressor run with T1 failure	0	30	7	min.	7
CT2	Compressor stop with T1 failure	0	30	3	min.	3
2CD	Start delay 2nd compressor	0	120	0	sec.	0
DFR	Defrost frequency / 24h	0	24	2	1/24h	2
DLI	Defrost end temperature	-40	40	20	°C	20
DTO	Maximum defrost duration	1	120	20	min.	20
DTY	Defrost type	OFF; ELE; GAS		OFF	flag	OFF
DRN	Drain down time	0	30	2	min.	2
DDY	Defrost display control	0	60	10	min.	10
FID	Fan activity during defrost	NO	YES	YES	flag	YES
FDD	Fan re-start delay temperature	-40	40	0	°C	0
FTO	Evaporator fan maximum time-out	0	120	3	min.	3
FTC	Evaporator fan timed control	NO	YES	YES	flag	YES
FT1	Fan stop delay	0	180	15	sec.	15
FT2	Timed fan stop	0	30	2	min.	2
FT3	Timed fan run	0	30	1	min.	1
ATL	Low alarm differential	-12	0	-5	°K	-5
ATH	High alarm differential	0	12	5	°K	5
ATD	Alarm Temperature Delay	0	120	90	min.	90
AHT	Condenser Alarm Temperature	0	75	60	°C	60
AHM	Condenser high temp. alarm operation	NON; ALR; STP		NON	flag	NON
ACC	Condenser cleaning period	0	52	0	wks	0
HDS	Sensitivity function eco / heavy duty	1	5	3	flag	3
IISM	2nd parameter set switching mode	NON; MAN; HDD; DI2		HDD	flag	HDD
IISL	Minimum 2nd temp. set	-40	IISH	1	°C	1
IISH	Maximum 2nd temp. set	IISL	40	3	°C	3
IISP	Effective 2nd temperature set point	IISL	IISH	1	°C	1
IIHY	Hysteresis 2nd temperature set	0.1	10	3	°K	3
IIFT	Evap. fan timed control in mode 2	NO	YES	NO	flag	NO
IIDF	Defrost Frequency / 24h in mode 2	0	24	4	1/24h	4
SB	Button 0/1 enabling	NO	YES	YES	flag	YES
DS	Door switch enabling	NO	YES	YES	flag	NO
CSD	Compressor stop delay from door opening	0	30	1	min.	1
ADO	Door alarm delay	0	30	8	min.	8
D12	Function digital input D12	NON; HPS; IISM; RDS		NON	flag	NON
LSM	Light switch mode	NON; MAN; DOR		NON	flag	NON
OAU	Control of AUX output	NON; 0-1; LGT; 2CU; 2EU; ALR		NON	flag	NON
OS1	T1 (air) probe offset	-12	12	0	°K	0
T2	T2 (evap.) probe enabling	NO	YES	NO	flag	NO
OS2	T2 (evap.) probe offset	-12	12	0	°K	0
T3	T3 (cond.) probe enabling	NO	YES	NO	flag	NO
OS3	T3 (cond.) probe offset	-12	12	0	°K	0
T4	T4 (aux.) probe enabling	NON; 2CU; 2EU		NON	flag	NON
OS4	T4 (aux.) probe offset	-12	12	0	°K	0
TLD	Delay for min./max. temp storage	1	30	5	min.	5
SIM	Display slowdown	0	100	3	exp.	3
ADR	Unit peripheral address	1	255	1	exp.	1

Parameter settings for the FSL400M and FSL800M

Mnem.	Definition	Min.	Max	Default	Dim.	M Temp
SCL	Readout scale	1°C; 2°C; °F		2	flag	2
SPL	Minimum set point [I]	-40	SPH	1	°C	-2
SPH	Maximum set point [I]	SPL	40	3	°C	0
SP	Set point [I]	SPL	SPH	2	°C	-1
HYS	Thermostat hysteresis [I]	0.1	10	3	°K	2
CRT	Minimum compressor rest time	0	30	2	min.	2
CT1	Compressor run with T1 failure	0	30	7	min.	7
CT2	Compressor stop with T1 failure	0	30	3	min.	3
2CD	Start delay 2nd compressor	0	120	0	sec.	0
DFR	Defrost frequency / 24h	0	24	2	1/24h	4
DLI	Defrost end temperature	-40	40	20	°C	20
DTO	Maximum defrost duration	1	120	20	min.	20
DTY	Defrost type	OFF; ELE; GAS		OFF	flag	ELE
DRN	Drain down time	0	30	2	min.	2
DDY	Defrost display control	0	60	10	min.	10
FID	Fan activity during defrost	NO	YES	YES	flag	NO
FDD	Fan re-start delay temperature	-40	40	0	°C	0
FTO	Evaporator fan maximum time-out	0	120	3	min.	3
FTC	Evaporator fan timed control	NO	YES	YES	flag	YES
FT1	Fan stop delay	0	180	15	sec.	15
FT2	Timed fan stop	0	30	2	min.	3
FT3	Timed fan run	0	30	1	min.	1
ATL	Low alarm differential	-12	0	-5	°K	-5
ATH	High alarm differential	0	12	5	°K	5
ATD	Alarm Temperature Delay	0	120	90	min.	90
AHT	Condenser Alarm Temperature	0	75	60	°C	60
AHM	Condenser high temp. alarm operation	NON; ALR; STP		NON	flag	NON
ACC	Condenser cleaning period	0	52	0	wks	0
HDS	Sensitivity function eco / heavy duty	1	5	3	flag	3
IISM	2nd parameter set switching mode	NON; MAN; HDD; DI2		HDD	flag	HDD
IISL	Minimum 2nd temp. set	-40	IISH	1	°C	-2
IISH	Maximum 2nd temp. set	IISL	40	3	°C	0
IISP	Effective 2nd temperature set point	IISL	IISH	1	°C	-2
IIHY	Hysteresis 2nd temperature set	0.1	10	3	°K	2
IIFT	Evap. fan timed control in mode 2	NO	YES	NO	flag	NO
IIDF	Defrost Frequency / 24h in mode 2	0	24	4	1/24h	4
SB	Button 0/1 enabling	NO	YES	YES	flag	YES
DS	Door switch enabling	NO	YES	YES	flag	NO
CSD	Compressor stop delay from door opening	0	30	1	min.	1
ADO	Door alarm delay	0	30	8	min.	8
D12	Function digital input D12	NON; HPS; IISM; RDS		NON	flag	NON
LSM	Light switch mode	NON; MAN; DOR		NON	flag	NON
OAU	Control of AUX output	NON; 0-1; LGT; 2CU; 2EU; ALR		NON	flag	NON
OS1	T1 (air) probe offset	-12	12	0	°K	0
T2	T2 (evap.) probe enabling	NO	YES	NO	flag	YES
OS2	T2 (evap.) probe offset	-12	12	0	°K	0
T3	T3 (cond.) probe enabling	NO	YES	NO	flag	NO
OS3	T3 (cond.) probe offset	-12	12	0	°K	0
T4	T4 (aux.) probe enabling	NON; 2CU; 2EU		NON	flag	NON
OS4	T4 (aux.) probe offset	-12	12	0	°K	0
TLD	Delay for min./max. temp storage	1	30	5	min.	5
SIM	Display slowdown	0	100	3	exp.	3
ADR	Unit peripheral address	1	255	1	exp.	1

Parameter settings for the FSL 400L and FSL800L

Mnem.	Definition	Min.	Max	Default	Dim.	L Temp
SCL	Readout scale	1°C; 2°C; °F		2	flag	2
SPL	Minimum set point [I]	-40	SPH	1	°C	-21
SPH	Maximum set point [I]	SPL	40	3	°C	-19
SP	Set point [I]	SPL	SPH	2	°C	-19
HYS	Thermostat hysteresis [I]	0.1	10	3	°K	3
CRT	Minimum compressor rest time	0	30	2	min.	2
CT1	Compressor run with T1 failure	0	30	7	min.	7
CT2	Compressor stop with T1 failure	0	30	3	min.	3
2CD	Start delay 2nd compressor	0	120	0	sec.	0
DFR	Defrost frequency / 24h	0	24	2	1/24h	4
DLI	Defrost end temperature	-40	40	20	°C	20
DTO	Maximum defrost duration	1	120	20	min.	20
DTY	Defrost type	OFF; ELE; GAS		OFF	flag	ELE
DRN	Drain down time	0	30	2	min.	2
DDY	Defrost display control	0	60	10	min.	10
FID	Fan activity during defrost	NO	YES	YES	flag	NO
FDD	Fan re-start delay temperature	-40	40	0	°C	0
FTO	Evaporator fan maximum time-out	0	120	3	min.	3
FTC	Evaporator fan timed control	NO	YES	YES	flag	YES
FT1	Fan stop delay	0	180	15	sec.	15
FT2	Timed fan stop	0	30	2	min.	3
FT3	Timed fan run	0	30	1	min.	1
ATL	Low alarm differential	-12	0	-5	°K	-5
ATH	High alarm differential	0	12	5	°K	5
ATD	Alarm Temperature Delay	0	120	90	min.	90
AHT	Condenser Alarm Temperature	0	75	60	°C	60
AHM	Condenser high temp. alarm operation	NON; ALR; STP		NON	flag	NON
ACC	Condenser cleaning period	0	52	0	wks	0
HDS	Sensitivity function eco / heavy duty	1	5	3	flag	3
IISM	2nd parameter set switching mode	NON; MAN; HDD; DI2		HDD	flag	HDD
IISL	Minimum 2nd temp. set	-40	IISH	1	°C	-21
IISH	Maximum 2nd temp. set	IISL	40	3	°C	-21
IISP	Effective 2nd temperature set point	IISL	IISH	1	°C	-21
IIHY	Hysteresis 2nd temperature set	0.1	10	3	°K	3
IIFT	Evap. fan timed control in mode 2	NO	YES	NO	flag	NO
IIDF	Defrost Frequency / 24h in mode 2	0	24	4	1/24h	4
SB	Button 0/1 enabling	NO	YES	YES	flag	YES
DS	Door switch enabling	NO	YES	YES	flag	NO
CSD	Compressor stop delay from door opening	0	30	1	min.	1
ADO	Door alarm delay	0	30	8	min.	8
D12	Function digital input D12	NON; HPS; IISM; RDS		NON	flag	NON
LSM	Light switch mode	NON; MAN; DOR		NON	flag	NON
OAU	Control of AUX output	NON; 0-1; LGT; 2CU; 2EU; ALR		NON	flag	NON
OS1	T1 (air) probe offset	-12	12	0	°K	0
T2	T2 (evap.) probe enabling	NO	YES	NO	flag	YES
OS2	T2 (evap.) probe offset	-12	12	0	°K	0
T3	T3 (cond.) probe enabling	NO	YES	NO	flag	NO
OS3	T3 (cond.) probe offset	-12	12	0	°K	0
T4	T4 (aux.) probe enabling	NON; 2CU; 2EU		NON	flag	NON
OS4	T4 (aux.) probe offset	-12	12	0	°K	0
TLD	Delay for min./max. temp storage	1	30	5	min.	5
SIM	Display slowdown	0	100	3	exp.	3
ADR	Unit peripheral address	1	255	1	exp.	1

High Temperature Models Wiring Diagram Using Foster Controller LF 28B2SE-B part number 00-555920

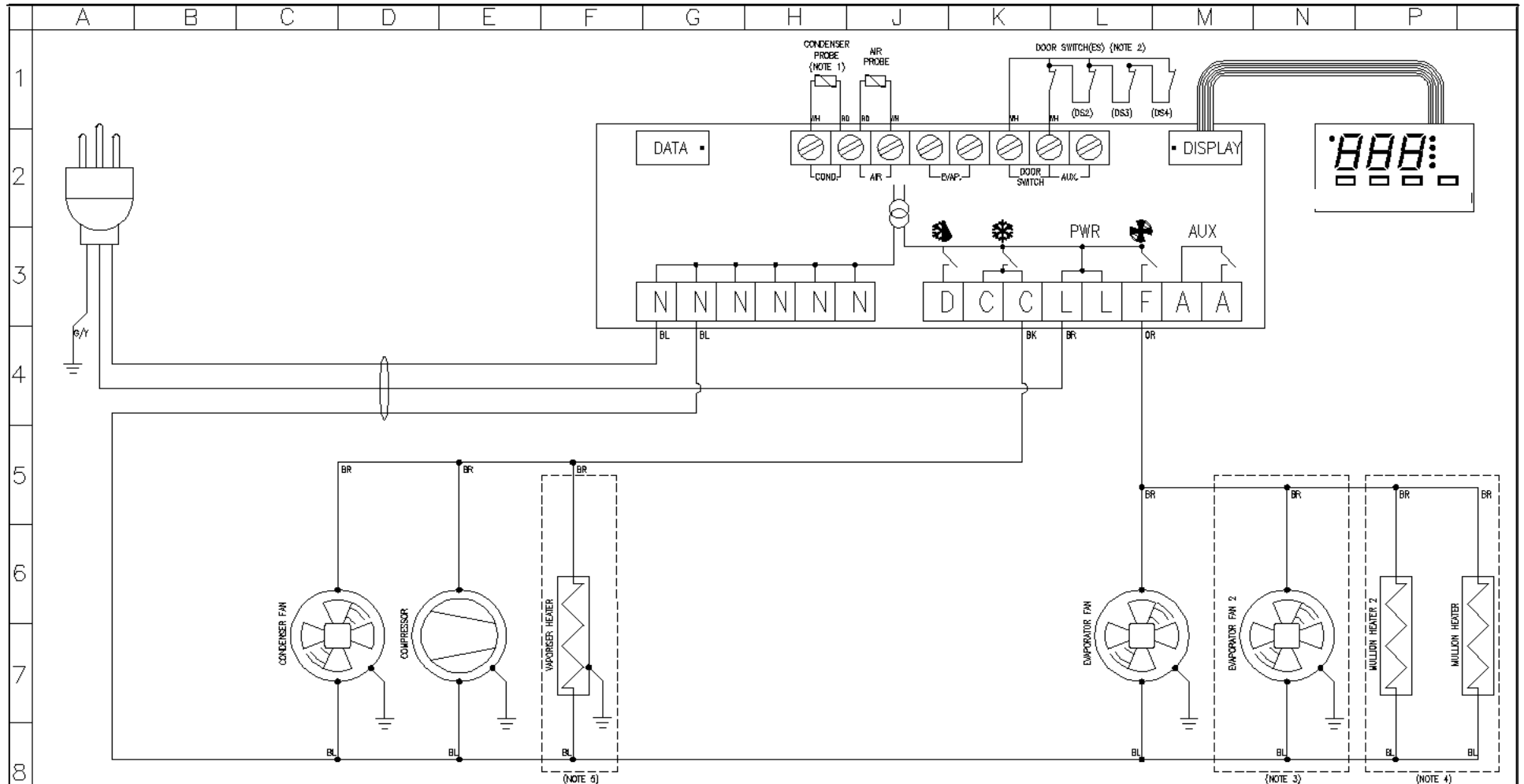

NOTES:

1. CONDENSER PROBE FITTED AS AN OPTION.
2. DOOR SWITCHES NOT FITTED TO 3X WINTER MODELS.
DS2 FITTED TO TWO DOOR CABINET MODELS WIRED IN SERIES TO DS1.
DS2, DS3 AND DS4 FITTED TO FOUR DOOR CABINET MODELS WIRED IN SERIES.
3. SECOND EVAPORATOR FAN FITTED TO LARGER CAPACITY MODELS.
4. NULLION HEATER(S) FITTED TO PREVENT NULLION SNEATING.
5. OPTIONAL VAPORISER HEATER CONNECTED DIRECTLY TO CONTROLLER.
6. CONTROLLER CONFIGURED FOR OFF CYCLE DEFROST.
7. ALL CABLE 1.0mm² UNLESS OTHERWISE STATED.
8. DOUBLE INSULATED CABLE: PLUS & SOCKET CONNECTION .
9. CABLE COLOUR CODE:
BR - BROWN RD - RED GY - GREY
BL - BLUE BK - BLACK YL - YELLOW
GY - GREEN / YELLOW WH - WHITE OR - ORANGE
(ALL EARTH WIRING TO BE GREEN/YELLOW)

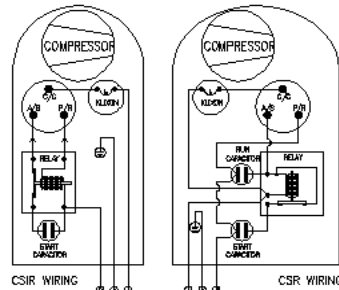

FOSTER REFRIGERATOR (U.K) LTD
OLDMEDCOW ROAD KING'S LYNN NORFOLK PE30 4JU

REV	DESCRIPTION	BY	DATE
01			







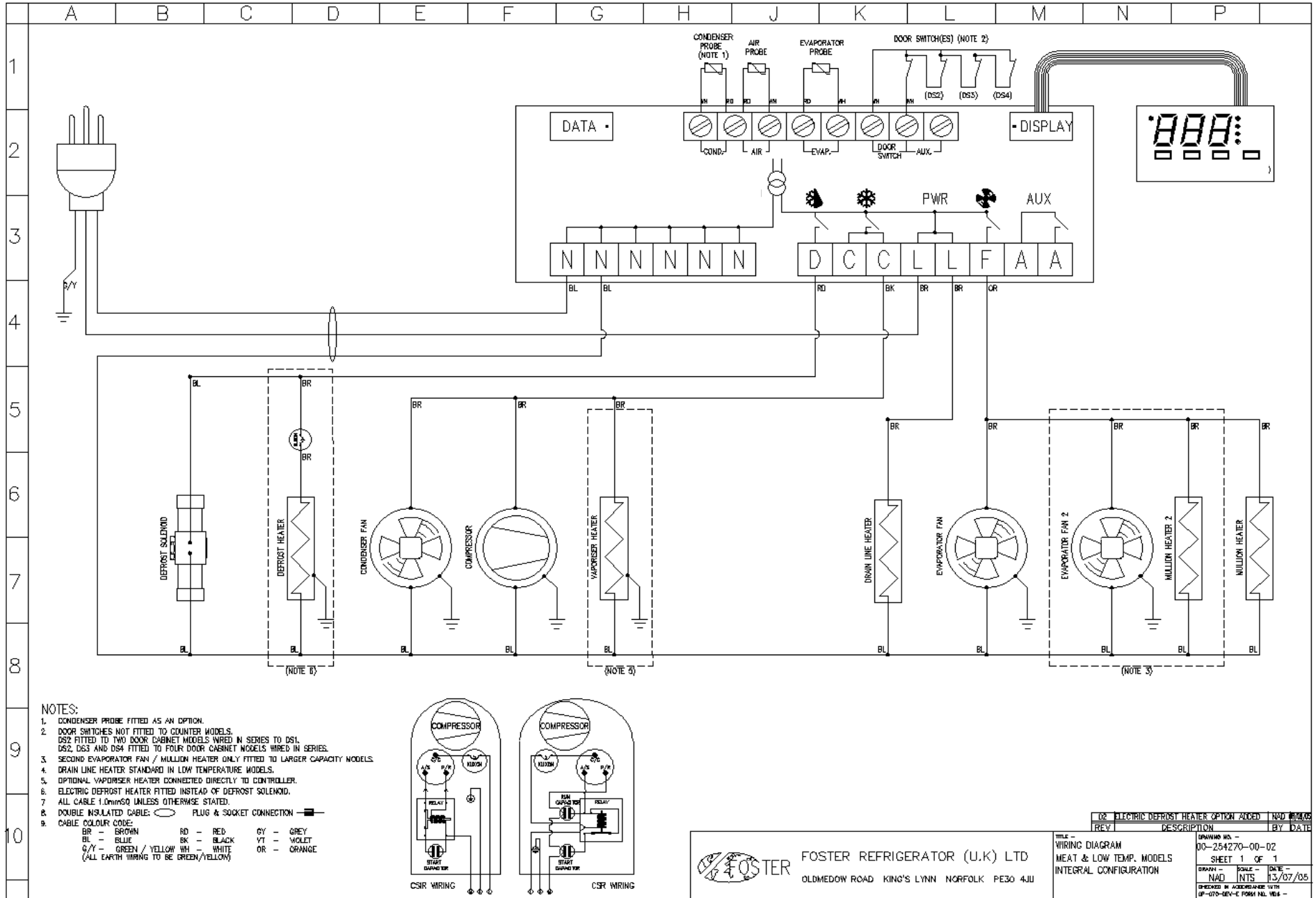



TITLE - WIRING DIAGRAM
HIGH TEMP. MODELS
INTEGRAL CONFIGURATION









DRAWN - NAD SCALE - DATE - 13/07/08
CHECKED IN ACCORDANCE WITH
DRAWING NO. - 00-254266-00-01
SHEET 1 OF 1

Meat & Low Temperature Models Wiring Diagram Using Foster Controller LF 28B2SE-B part number 00-555920



Troubleshooting

Problem	Possible Cause	Solution	
Compressor will not start	No voltage in socket	Use voltmeter to check	
	Electrical conductor or wires may be cut	Use ohmmeter to check for continuity	
	 Defective electrical component: thermostat, relay, thermal protector etc	Replace defective component	
	Compressor motor has a winding open or shorted	Measure ohmic resistance of main and auxiliary winding using ohmmeter. Compare with correct values	
	 Compressor stuck	Change compressor	
	Temperature control contacts are open	Repair or replace the contacts	
	Incorrect wiring	Check wiring diagram and correct	
	Fuse blown or circuit breaker tripped.	Replace fuse or reset circuit breaker	
	Power cord unplugged	Plug in power cord.	
	Controller set too high	Set controller to lower temperature.	
	Cabinet in defrost cycle	Wait for defrost cycle to finish	
	The temperature is too cold	Controller is set at a very cold position	Set to warmer position and check if the compressor stops according to controllers operating range.
		Controller does not disconnect the condensing unit	Check the insulation of the thermostat. If problem persists, change the thermostat
Control contacts are stuck closed		Change the control. Check amperage load	
Defective or incorrect temperature control		Determine correct control and replace.	
The temperature is not cold enough		Controller is set at a very warm position	Adjust to colder setting
	 Condenser is dirty	Clean condenser	
	 The refrigerator has been placed at an inadequate location	The unit must not be near stoves, walls that are exposed to the sun, or places that lack sufficient air flow.	
	 Compressor is inefficient or there is a high pressure due to the air in the system	If there is air in the system, purge and recharge	
	  Iced up evaporator coil	Check temperature control, refrigerant charge, and defrost mechanism. Remove all ice manually and start over.	
	Restriction in system	Locate exact point of restriction and correct	
	 The refrigerator has been used improperly	The shelves must never be covered with any type of plastic or other material that will block the circulation of cold air within the refrigerator.	
	 Too many door openings	Advise user to decrease if possible	
	 Excessive heat load placed in cabinet	Advise user not to put in products that are too hot.	
	 The refrigerator has been overcharged with the refrigerant gas	Check to see if condensation or ice crystals have formed on the suction line. If so, charge with the correct amount of gas.	

		The refrigerant gas is leaking	Find the location of gas leak in order to seal and replace the defective component. Change the drier. Perform a good vacuum and recharge unit.
	 	The evaporator and/or condenser fans are not working	Check electrical connections and make sure that the fan blade isn't stuck. Replace the fan motor if it doesn't work.
		Blocking air flow	Re-arrange product to allow for proper air flow. Make sure there is at least four inches of clearance from evaporator.
		Fuse blown or circuit breaker tripped	Replace fuse or reset circuit breaker.
Electrical Shocks		Wires or electrical components are in direct contact with metallic parts.	Check for appropriate insulation on the connections of each component.
Noise		The refrigerator is not properly levelled	Check if the noise goes away after you level the refrigerator
		The condenser is not fastened correctly. Copper tubing is in contact with metal	While the compressor is working, check to see if metal parts are in contact with one another and/or if the screws that fasten the condenser are tightened.
		The evaporator and/or condenser fans are loose	Check if the fans are securely fastened. Also, check if the fan blades are loose, broken or crooked. If so, change the faulty blade.
		Compressor has an internal noise	If the noise persists after all other measures have been taken, it may be originating from the compressor.
		Loose part(s)	Locate and tighten loose part(s)
Extreme condensation inside the refrigerator		Controller is set at a very cold position	Set the controller to a warmer position & check to see if compressor stops as should.
		The outside environment's relative humidity is very high (over 75%)	This type of occurrence is caused by local climatic conditions and not by the refrigeration unit.
		The refrigerator door wont shut completely	Check the door and/or the magnetic gasket. Adjust the door hinges if needed; replace the gasket if broken.
		The refrigerator had been placed at an inadequate location	The unit must not be near sources that produce too much heat.
No illumination (Glass door models only)		The light switch is "off" position	Press the light switch to "on" position
		False contact on the light switch, the fluorescent tube, or the ballast	Inspect all connections
		Light switch, ballast and/or fluorescent tube are damaged	Replace the damaged component.
Condensing unit runs for long periods of time		Excessive amount of warm product placed in cabinet	Advise user to leave adequate time for products to cool down
		Prolonged door opening or door ajar	Advise user to ensure doors are closed when not in use and to avoid opening doors for long periods of time.
		Door gasket(s) not sealing properly	Ensure gaskets are snapped in completely. Remove gasket and wash with soap and water. Check condition of gasket & replace if necessary

	Dirty condenser coil	Clean condenser coil
	Evaporator coil iced over	Unplug unit and allow coil to defrost. Make sure thermostat is not set too cold. Ensure that door gasket(s) are sealing properly. Select manual defrost and ensure system works.

Notes



Foster European Operations

France

Foster Refrigerator France SA

Tel: (33) 01 34 30 22 22. Fax: (33) 01 30 37 68 74.

Email: commercial@fosterfrance.com

Germany

Foster Refrigerator Gmbh,

Tel: (49) 781 990 7840. Fax (49) 781 990 7844.

Email: info@foster-gmbh.de

Foster Refrigerator

Oldmedow Road

Kings Lynn

Norfolk

PE30 4JU

Tel: 0843 216 8833

Fax: 0843 216 4707

Website: www.fosterrefrigerator.co.uk

Email: support@foster-uk.com

a Division of 'ITW (UK) Ltd'

SLIMLINE LF28/SM 07/10